



Excitation Techniques Do's and Don'ts



Peter Avitabile
UMASS Lowell

Marco Peres
The Modal Shop

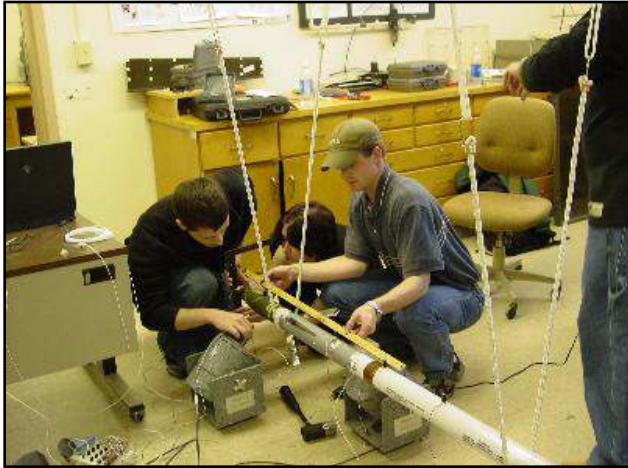
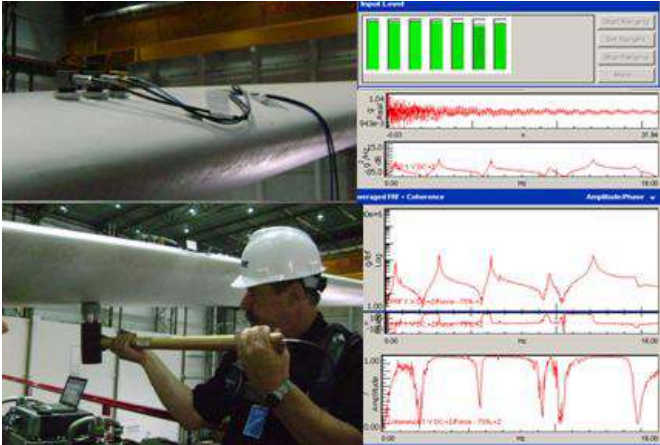

Excitation Considerations

Objectives of this lecture:

- *Overview impact testing considerations - part 1*
- *Overview shaker testing considerations - part 2*

- *Identify some typical concerns*
- *Provide some examples*

IMAC 27 presentation covered shaker excitation techniques

IMAC 29 presentation covered shaker testing considerations



MODAL SPACE - In Our Own Little World

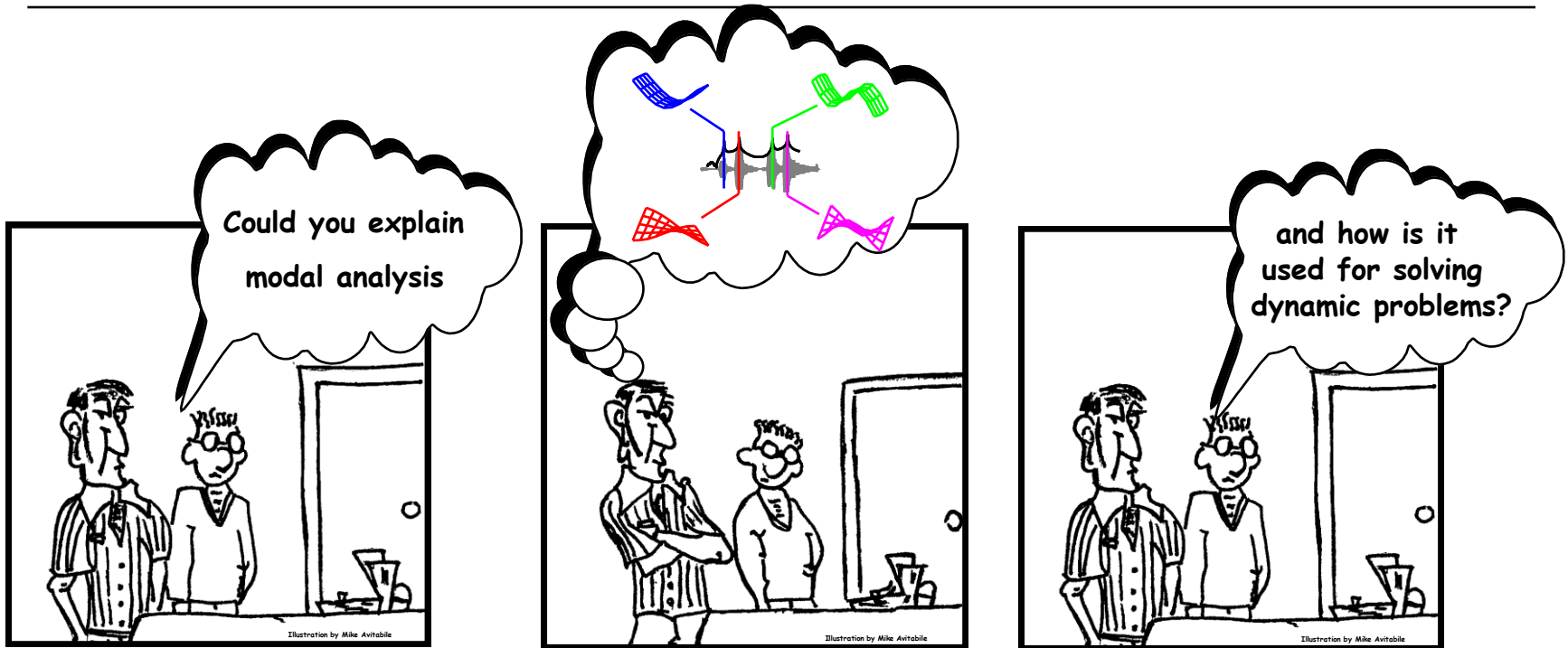

<http://sdasl.uml.edu/umlspace/mspace.html>



Series of articles on various aspects of modal analysis currently in its 15th continuous year of publication

Measurement Definitions - Refresher

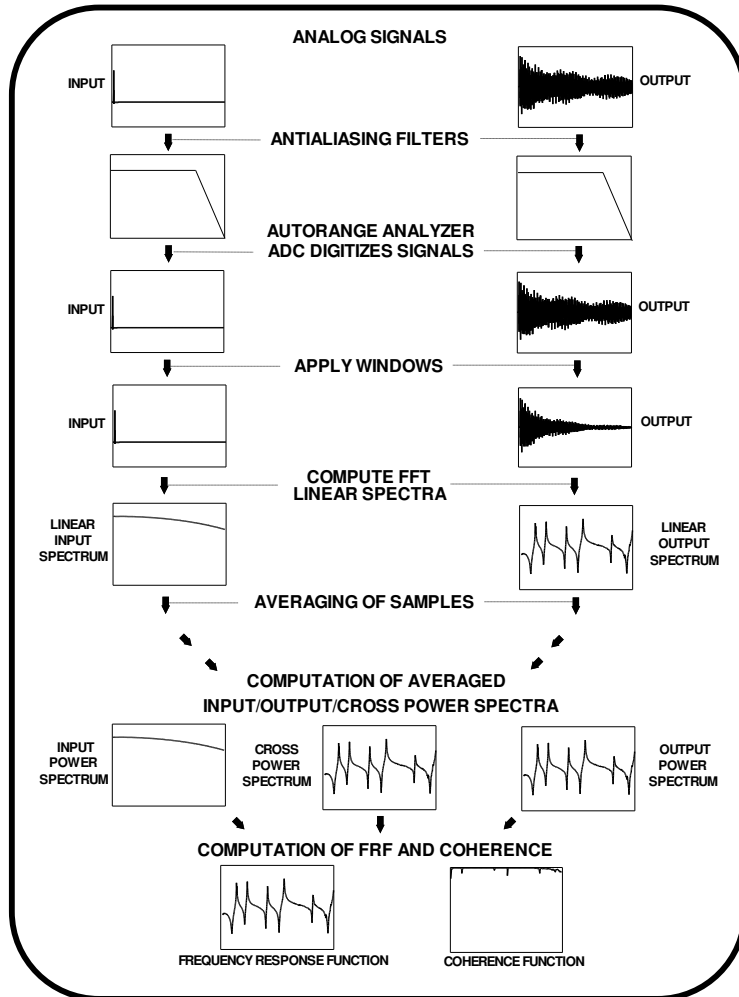

Actual time signals

Analog anti-alias filter

Digitized time signals

Windowed time signals

Compute FFT of signal

Average auto/cross spectra

Compute FRF and Coherence

Measurements - Linear Spectra - Refresher

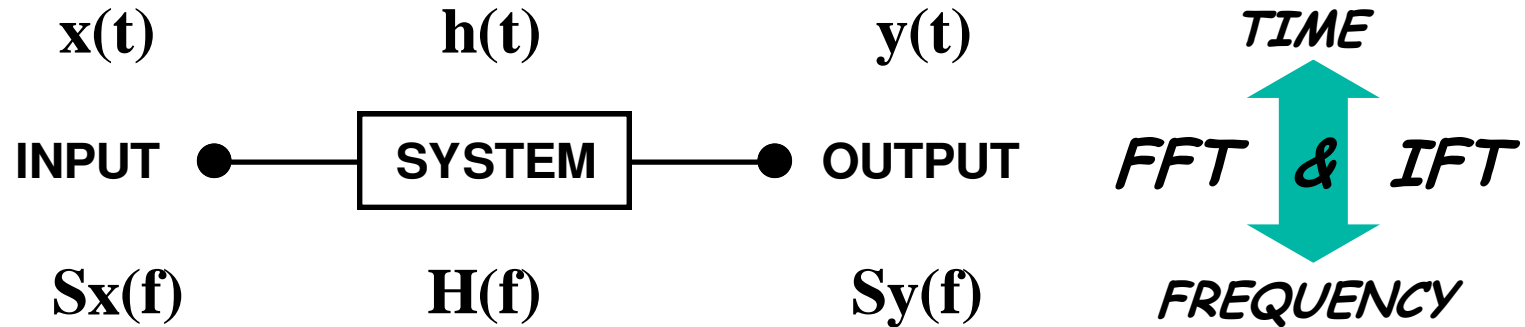

$x(t)$ - time domain input to the system

$y(t)$ - time domain output to the system

$S_x(f)$ - linear Fourier spectrum of $x(t)$

$S_y(f)$ - linear Fourier spectrum of $y(t)$

$H(f)$ - system transfer function

$h(t)$ - system impulse response

Measurements - Power Spectra - Refresher

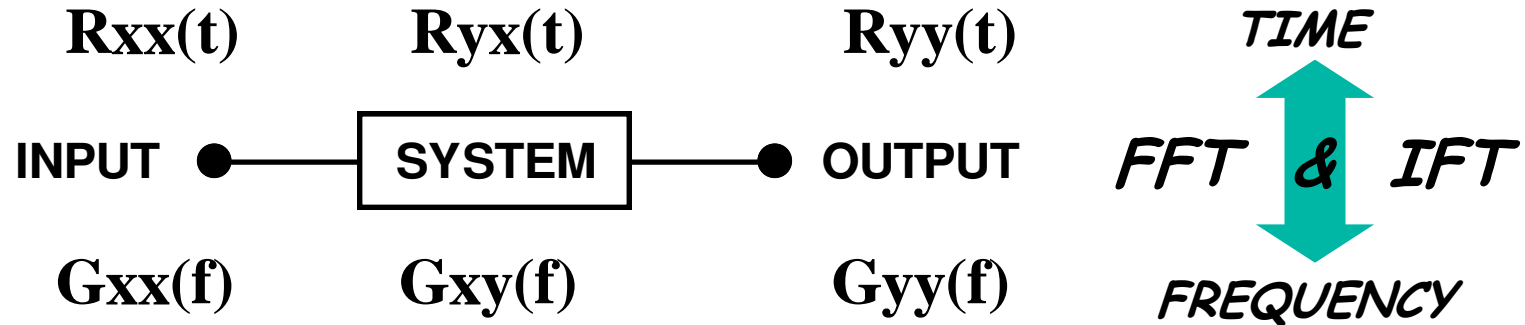

$R_{xx}(t)$ - autocorrelation of the input signal $x(t)$

$R_{yy}(t)$ - autocorrelation of the output signal $y(t)$

$R_{yx}(t)$ - cross correlation of $y(t)$ and $x(t)$

$G_{xx}(f)$ - autopower spectrum of $x(t)$

$$G_{xx}(f) = S_x(f) \cdot S_x^*(f)$$

$G_{yy}(f)$ - autopower spectrum of $y(t)$

$$G_{yy}(f) = S_y(f) \cdot S_y^*(f)$$

$G_{yx}(f)$ - cross power spectrum of $y(t)$ and $x(t)$

$$G_{yx}(f) = S_y(f) \cdot S_x^*(f)$$

Measurements - Derived Relationships - Refresher

$$S_y = HS_x$$

H1 formulation

- susceptible to noise on the input
- underestimates the actual H of the system

$$S_y \bullet S_x^* = HS_x \bullet S_x^* \quad H = \frac{S_y \bullet S_x^*}{S_x \bullet S_x^*} = \frac{G_{yx}}{G_{xx}}$$

H2 formulation

- susceptible to noise on the output
- overestimates the actual H of the system

$$S_y \bullet S_y^* = HS_x \bullet S_y^* \quad H = \frac{S_y \bullet S_y^*}{S_x \bullet S_y^*} = \frac{G_{yy}}{G_{xy}}$$

Other formulations for H exist

COHERENCE

$$\gamma_{xy}^2 = \frac{(S_y \bullet S_x^*)(S_x \bullet S_y^*)}{(S_x \bullet S_x^*)(S_y \bullet S_y^*)} = \frac{G_{yx} / G_{xx}}{G_{yy} / G_{xy}} = \frac{H_1}{H_2}$$

Typical Measurements - Refresher

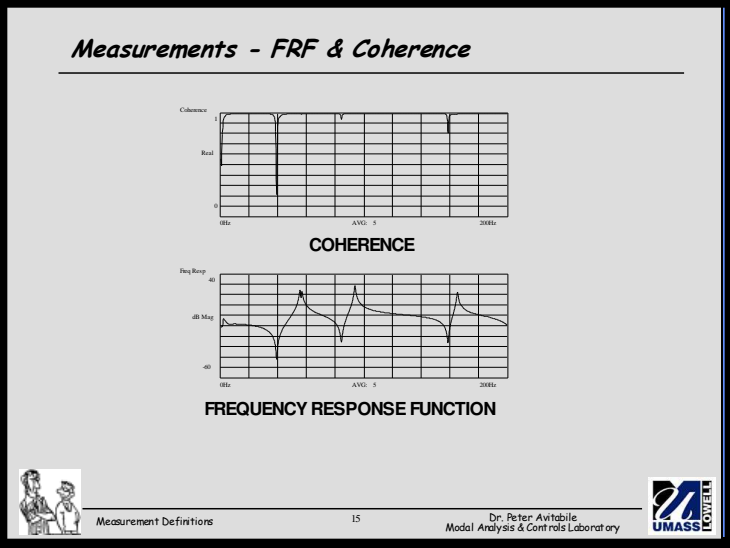
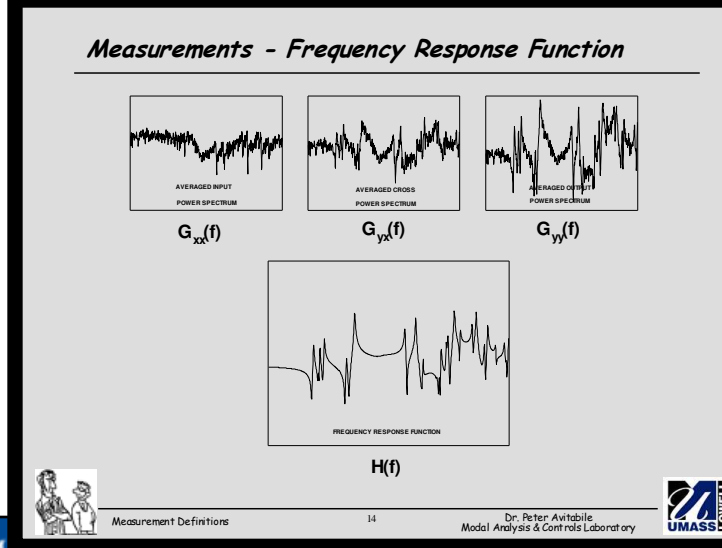
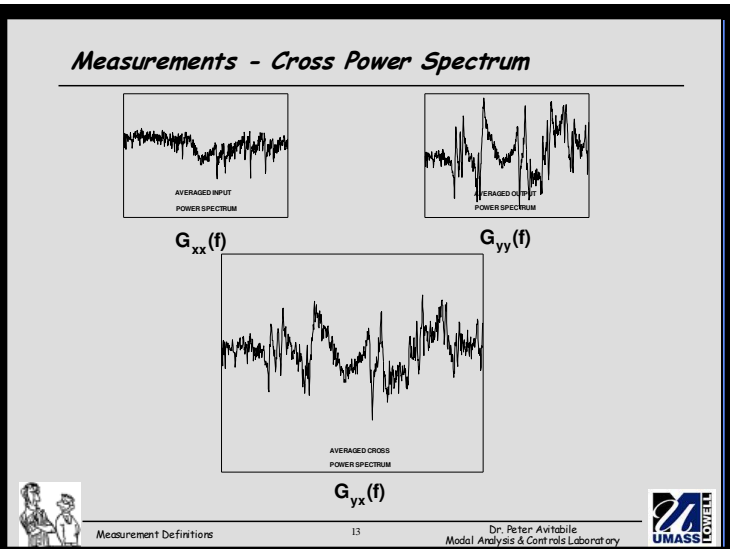
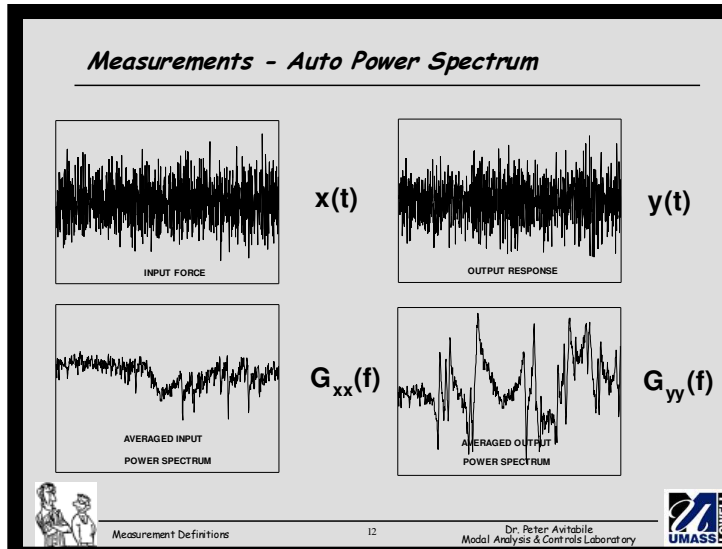

Impact Excitation

IMAC 30 - Jacksonville, FL - 2012

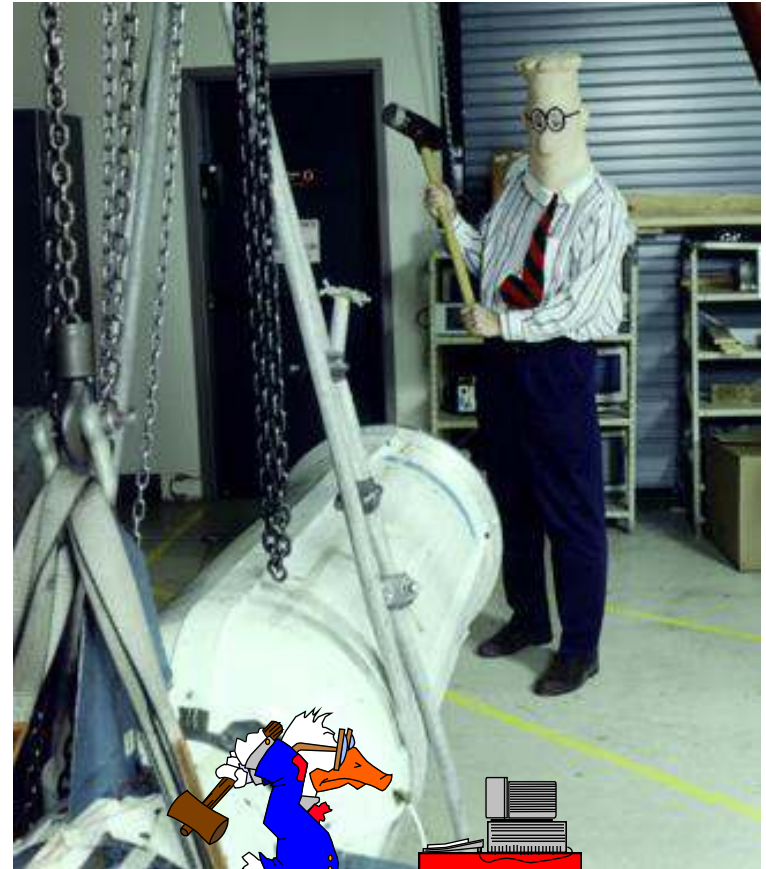
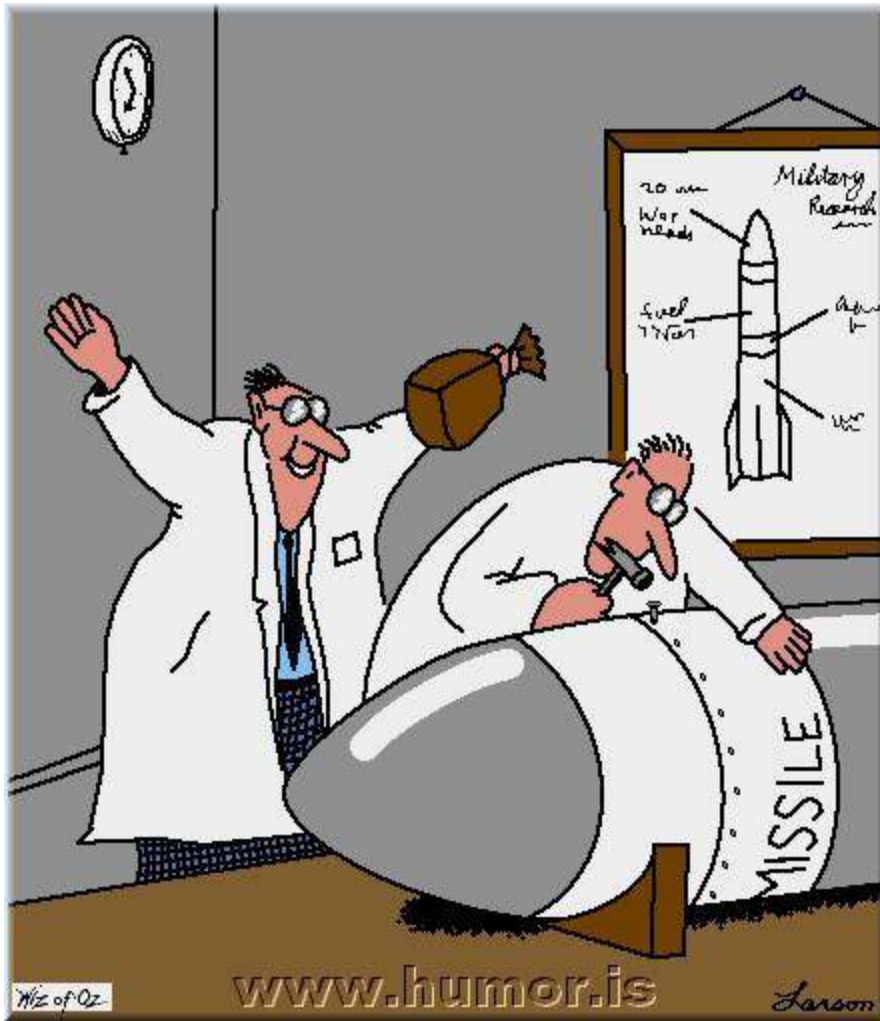

Impact Excitation

Objectives of this lecture:

- *Overview impact excitation techniques*
- *Review hammer/tip characteristics*
- *Review special DSP considerations*
- *Identify areas of concern and things to consider*



Impact Excitation

An impulsive excitation which is very short in the time window usually lasting less than 5% of the sample interval.

ADVANTAGES

- *easy setup*
- *fast measurement time*
- *minimum of equipment*
- *low cost*

CONSIDERATIONS

- *poor rms to peak levels*
- *poor for nonlinear structures*
- *force/response windows needed*
- *pretrigger delay needed*
- *double impacts may occur*
- *high potential for signal overload and underload of ADC*

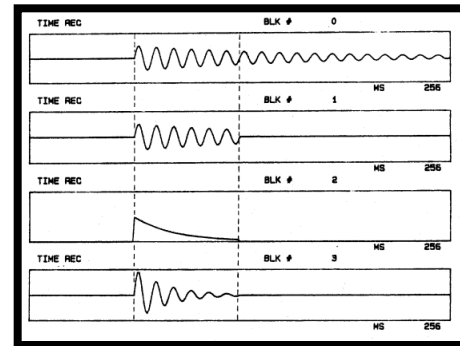
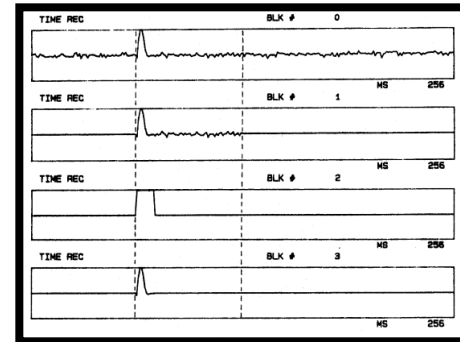

Practical Modal Impact Test Checklist

- *General*
 - *Range settings for channels*
 - *Frequency range - bandwidth - BW*
- *Hammer*
 - *Pre-trigger settings*
 - *Hammer tip selection*
 - *Windows*
- *Response*
 - *Windows*
- *FRF / Coherence*
 - *Measurement considerations*

Impact Excitation - Hammer Tip Selection

The force spectrum can be customized to some extent through the use of hammer tips with various hardnesses.

A hard tip has a very short pulse and will excite a wide frequency range. A soft tip has a long pulse and will excite a narrow frequency range.

However, the hammer tip alone does not totally determine the frequency range excited. The local flexibility of the structure must also be considered.

Impact Excitation - Hammer Tip Selection

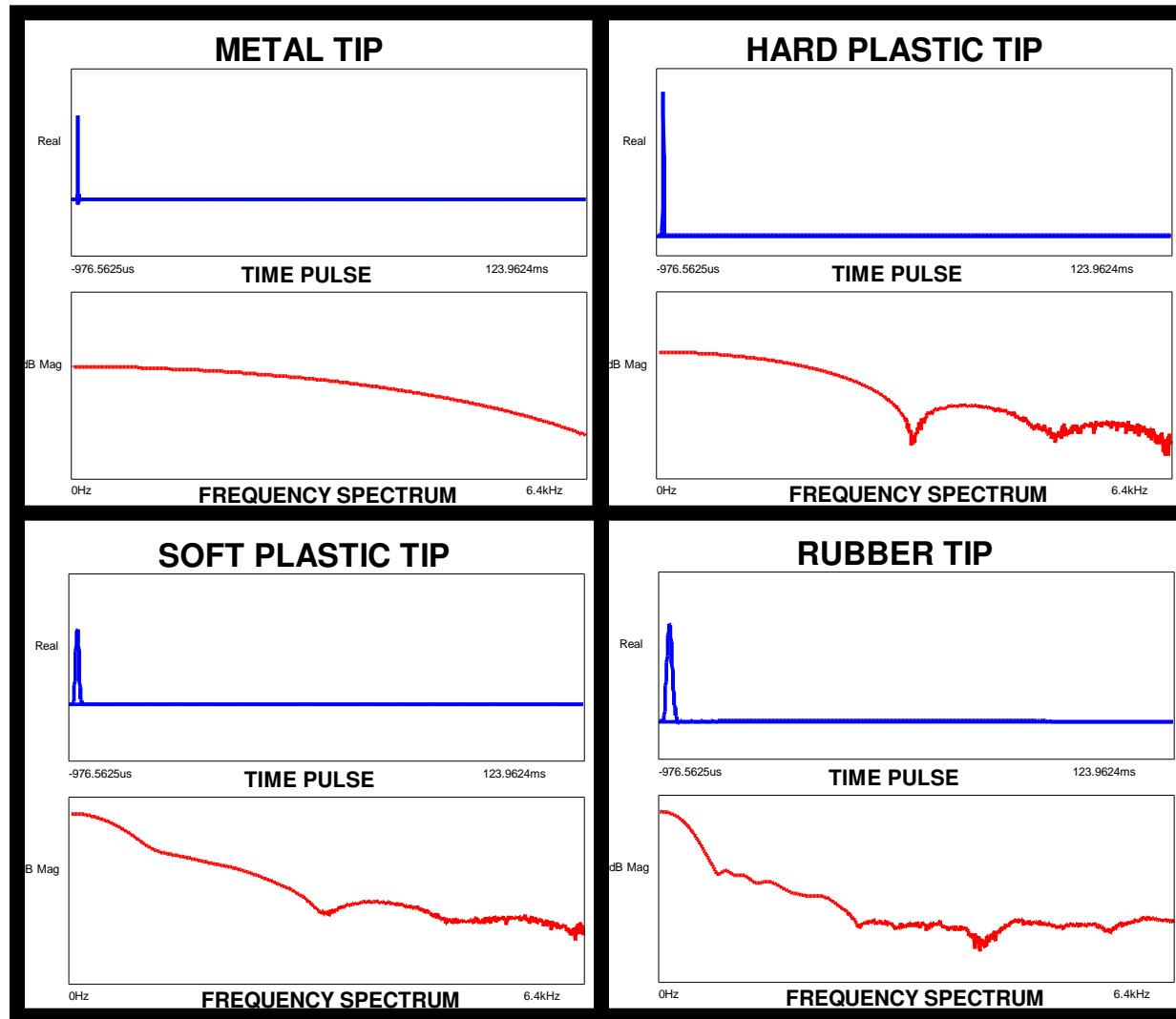

Impact Test - Pretrigger Delay - Sometimes Confusing

If the leading portion of the time pulse is not captured then there will be a distortion of the measured input spectrum

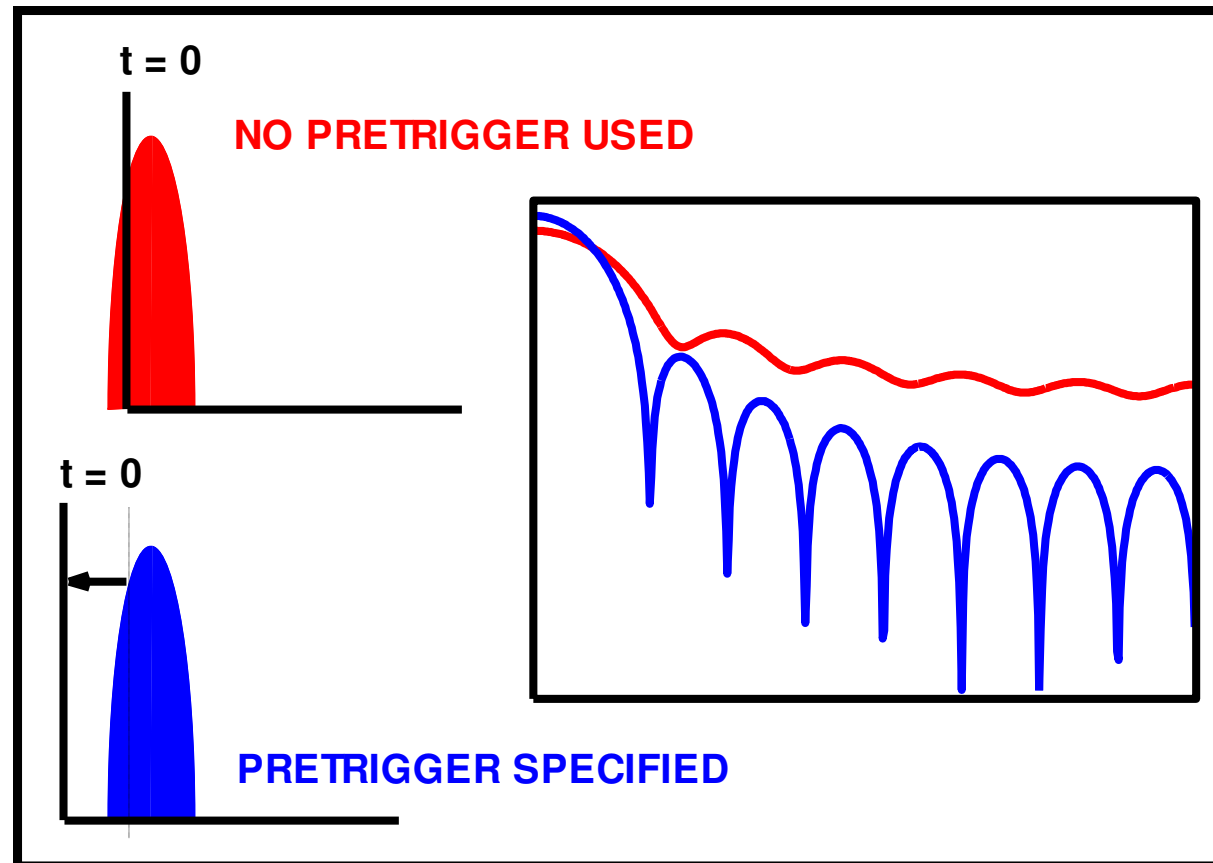

Impact Test - Double Impact

Double impacts can occur due to a sloppy hammer swing or many times due to the responsive nature of many structures. They should be avoided wherever possible.

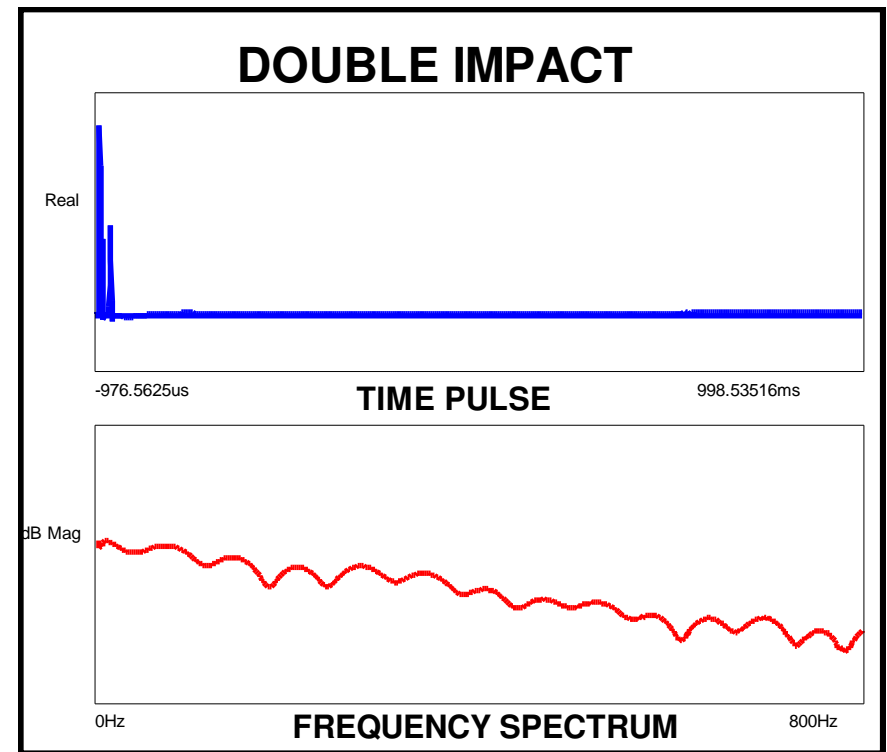
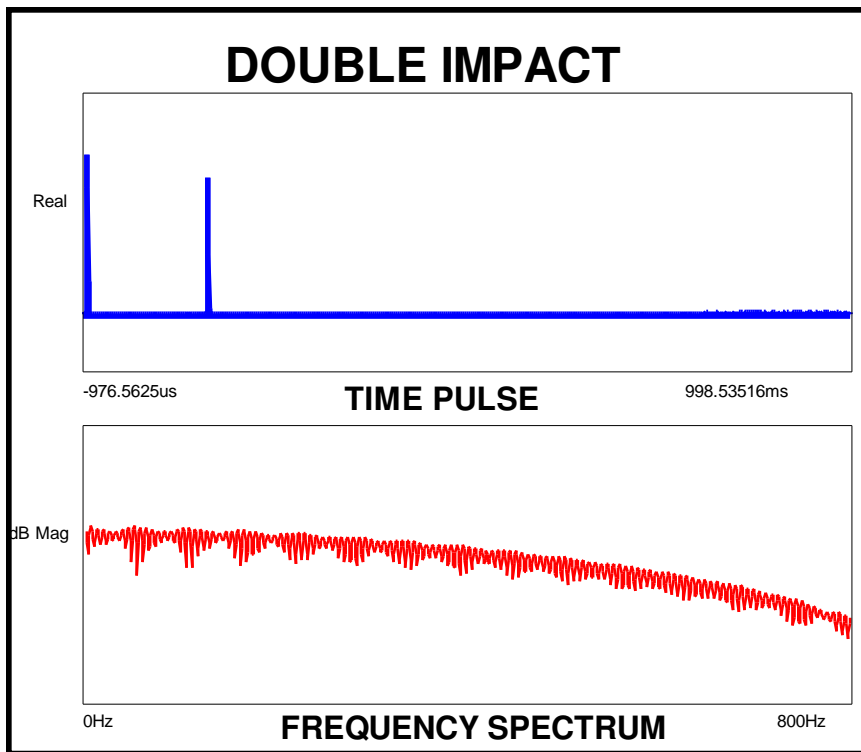

Impact Excitation - Windows May Be Necessary

If response does not die out then a window may be required

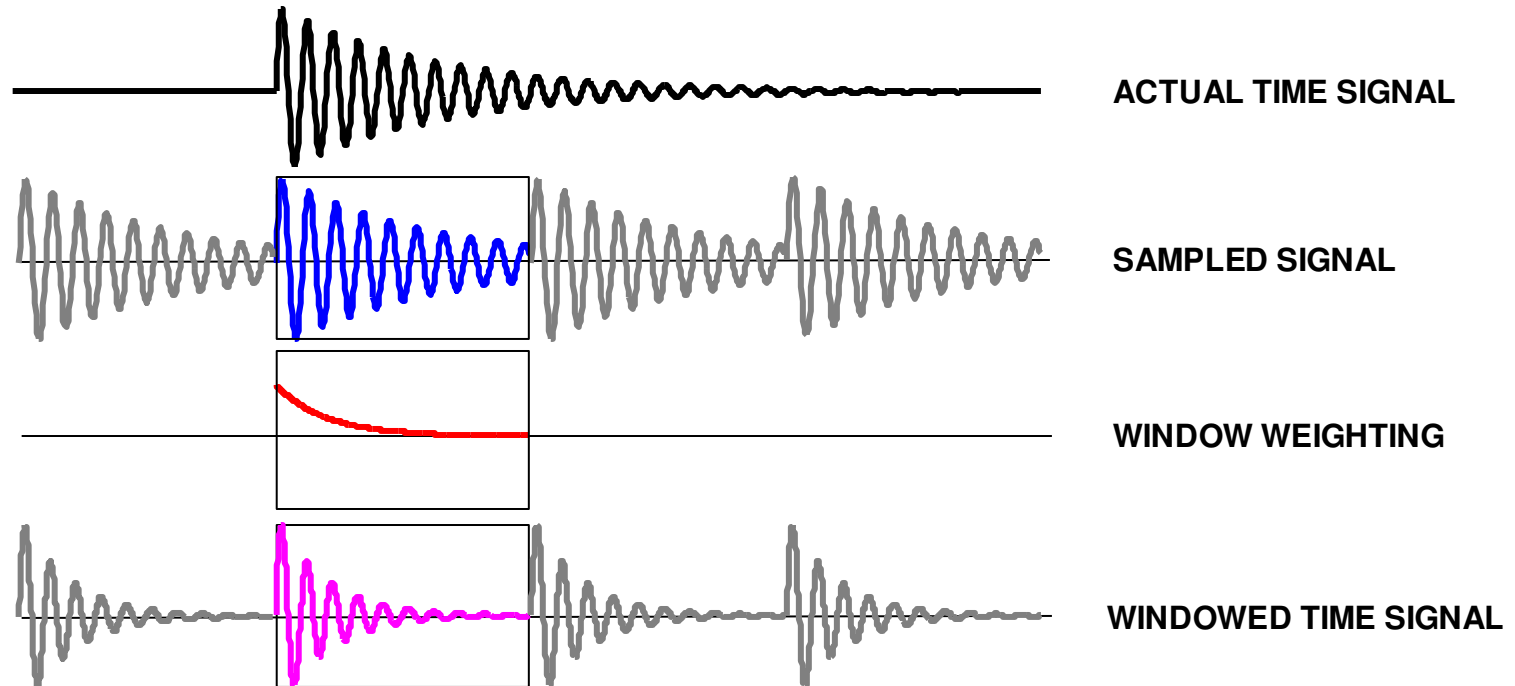

Impact Excitation - Exponential Window

If the signal does not naturally decay within the sample interval, then an exponentially decaying window may be necessary.

However, many times changing the signal processing parameters such as bandwidth and number of spectral lines may produce a signal which requires less window weighting

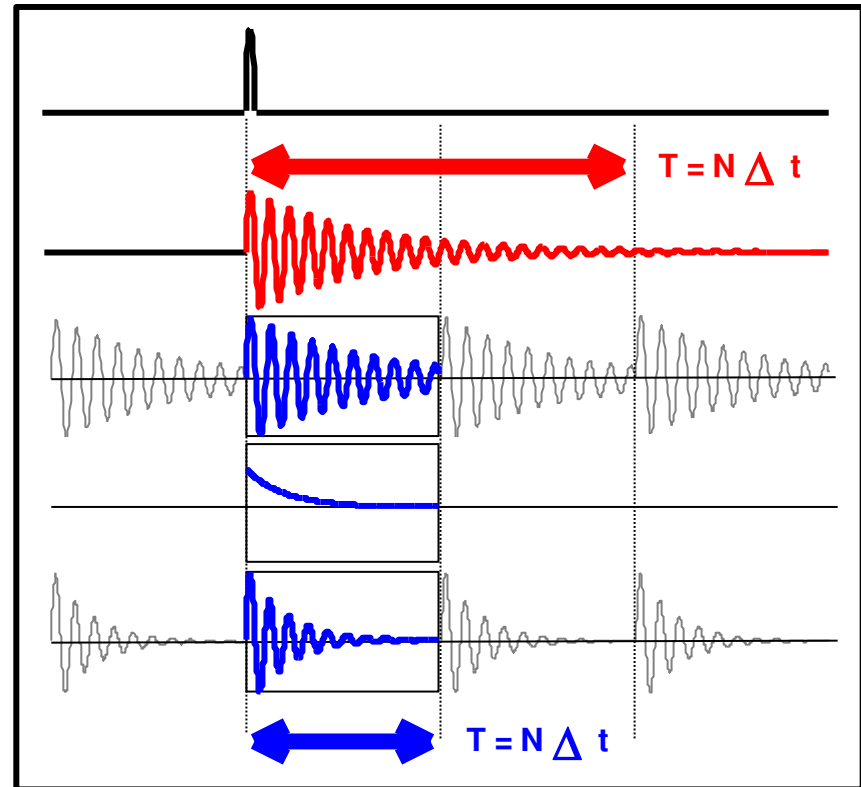

Impact Excitation - Force & Exponential Window

IMAC 2008

Use of the Force Window

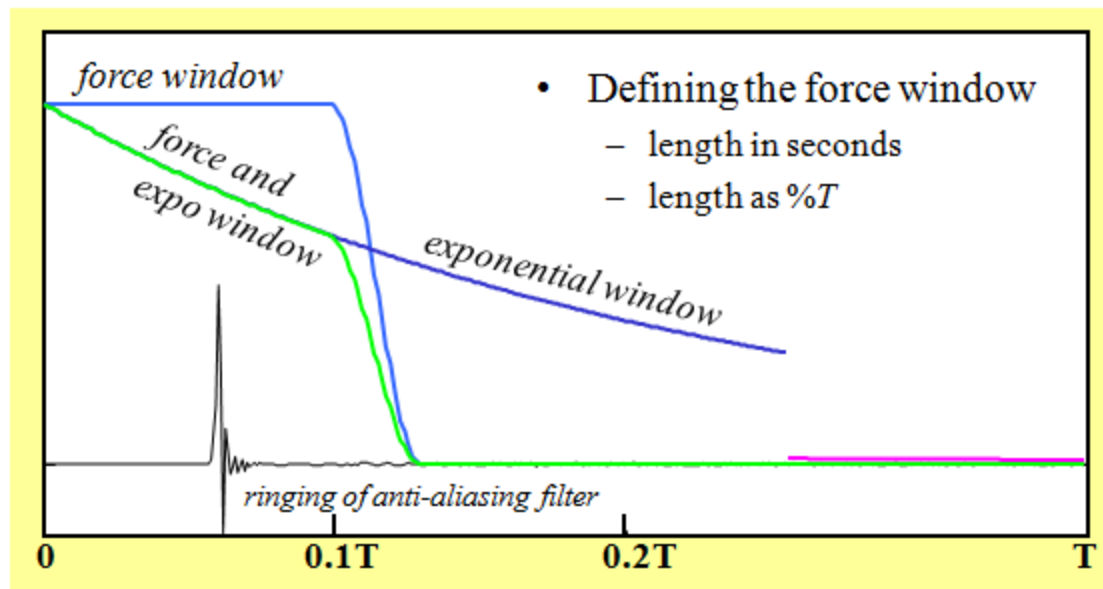

- The "length" of the force window = the duration of the leading unity portion

20

IMAC-XXVI -- Modal Excitation -- Dave Brown University of Cincinnati

Impact Excitation - Right Hammer for the Test

Measurement adequacy depends on what is required

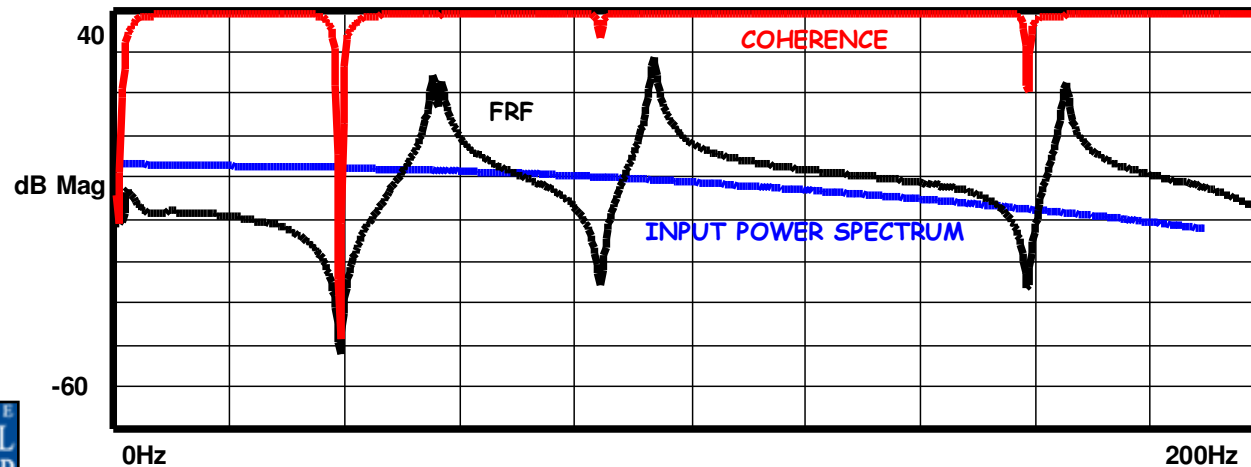
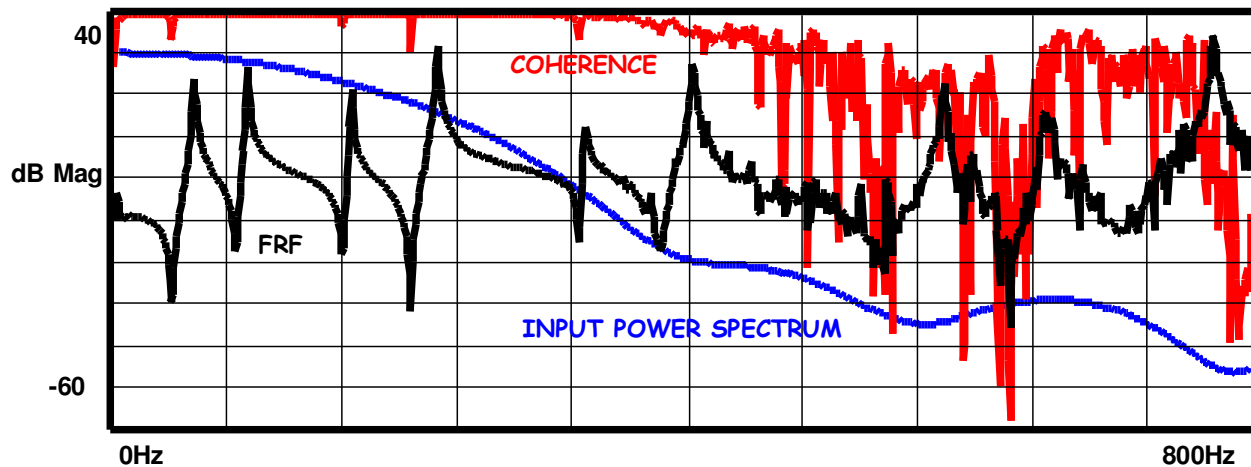

Impact at One Point - Listen at Another - What FRF?

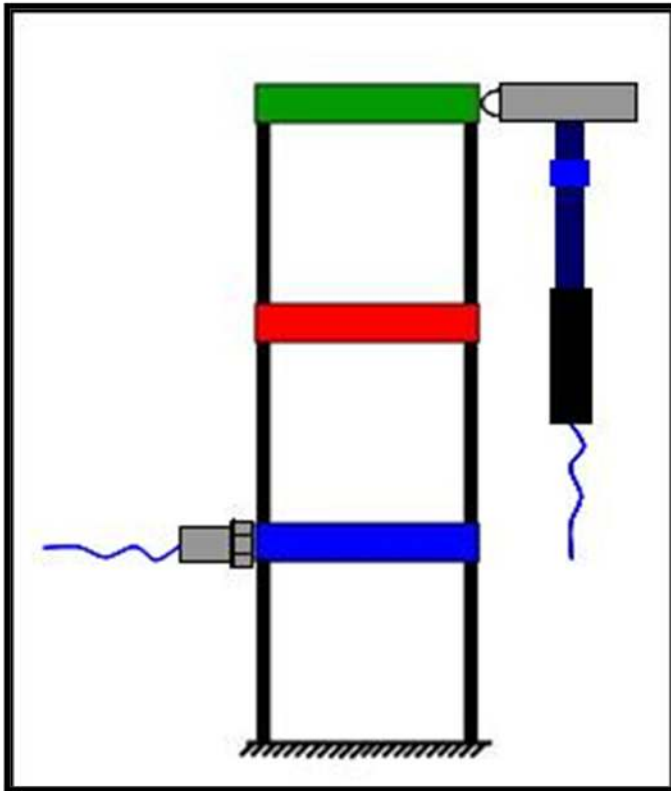

Magnitude

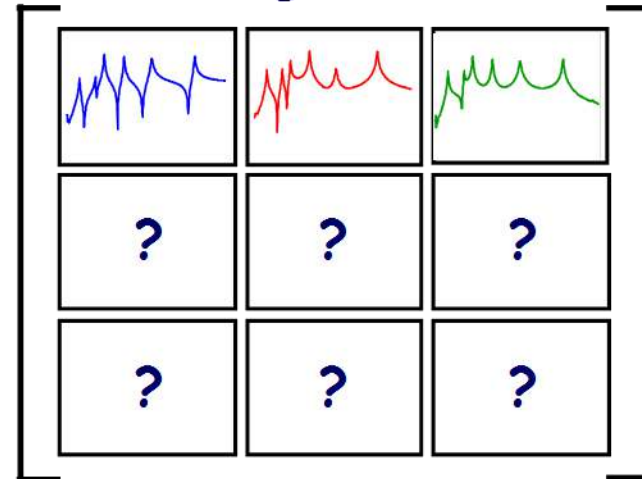

Imaginary

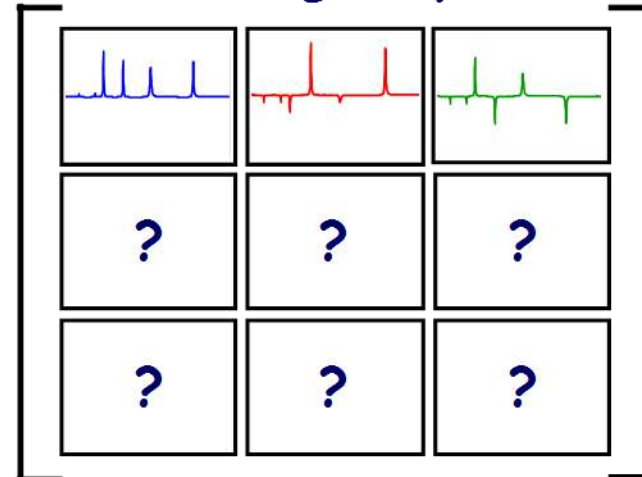

$$H_{out/in} = H_{row/col}$$

Impact at One Point - Listen at Another - What FRF?

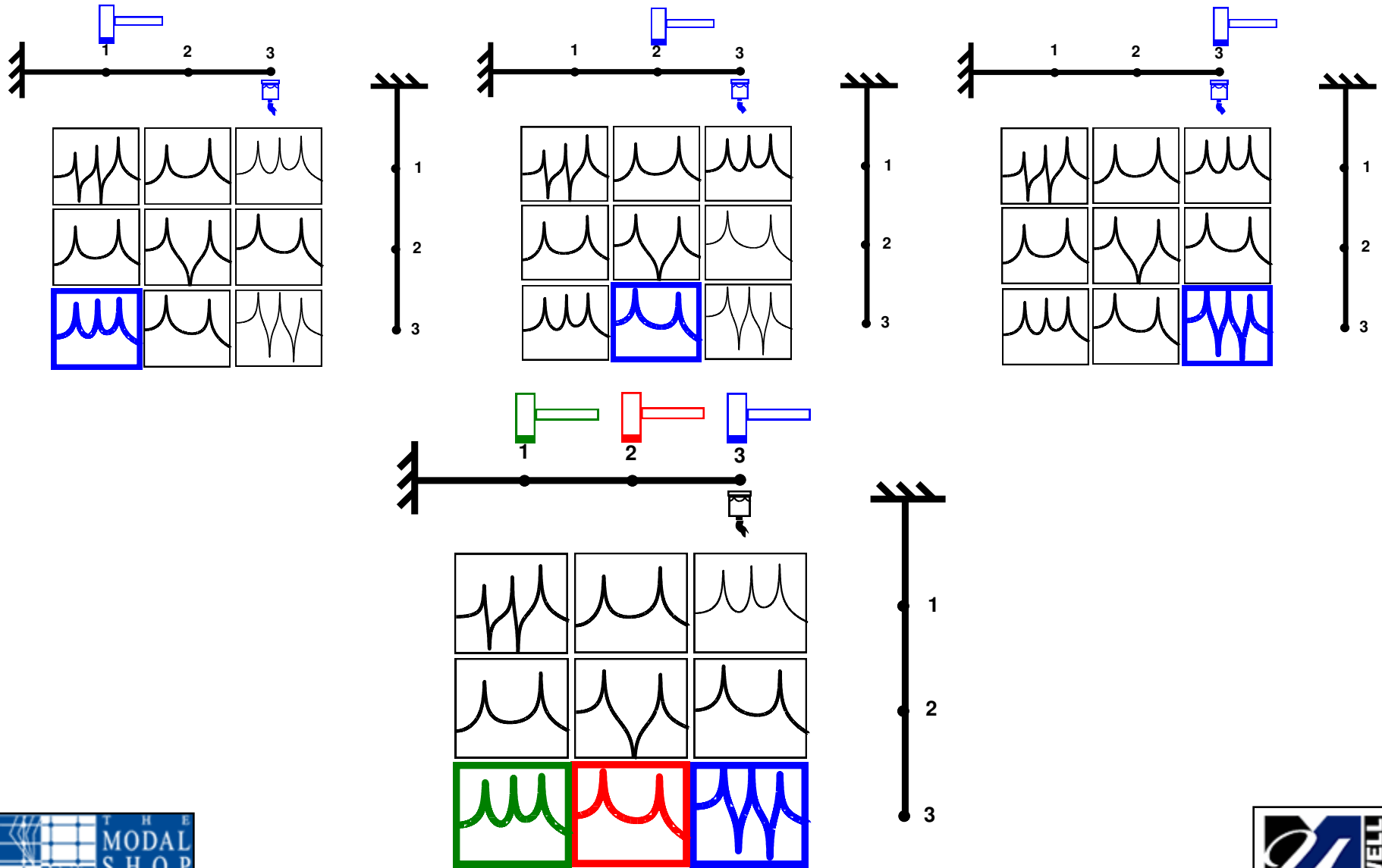

Drive Point Measurements

Drive point measurement

Same input and output location - in the same direction

Response at 4

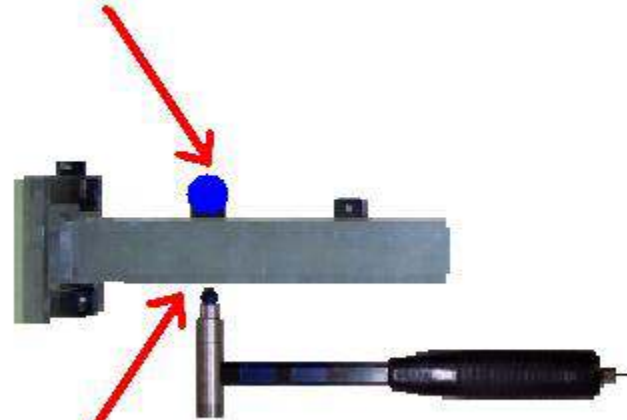

Input at 4

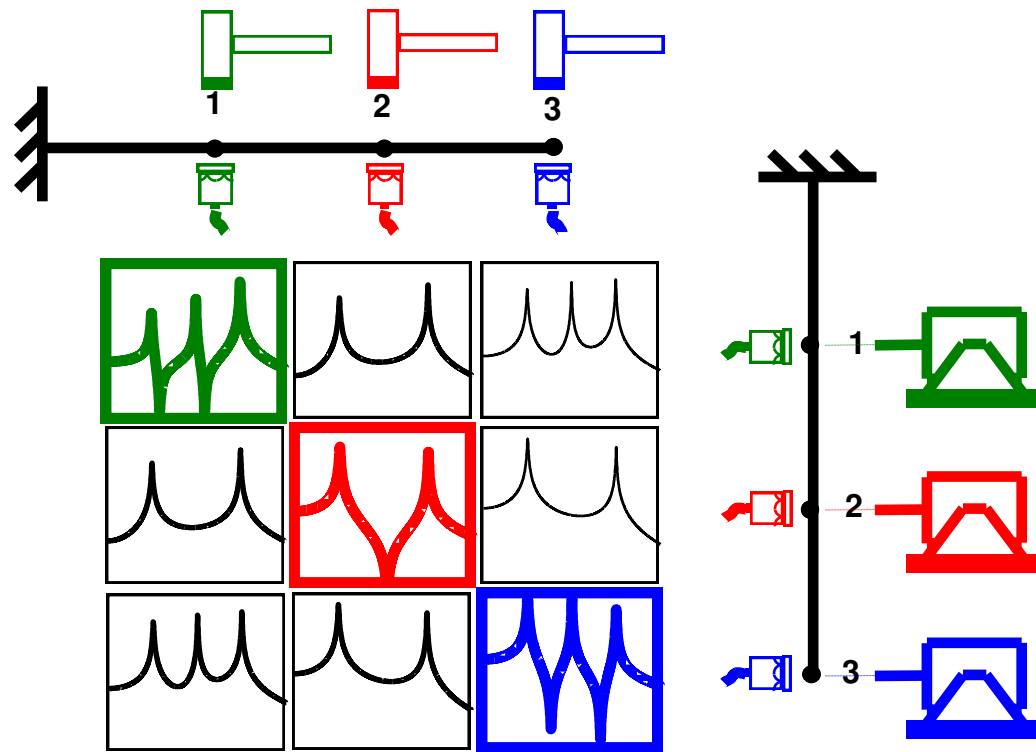

Reciprocity - $H_{out/in} = H_{ij}$

Reciprocity is an underlying necessity for modal theory

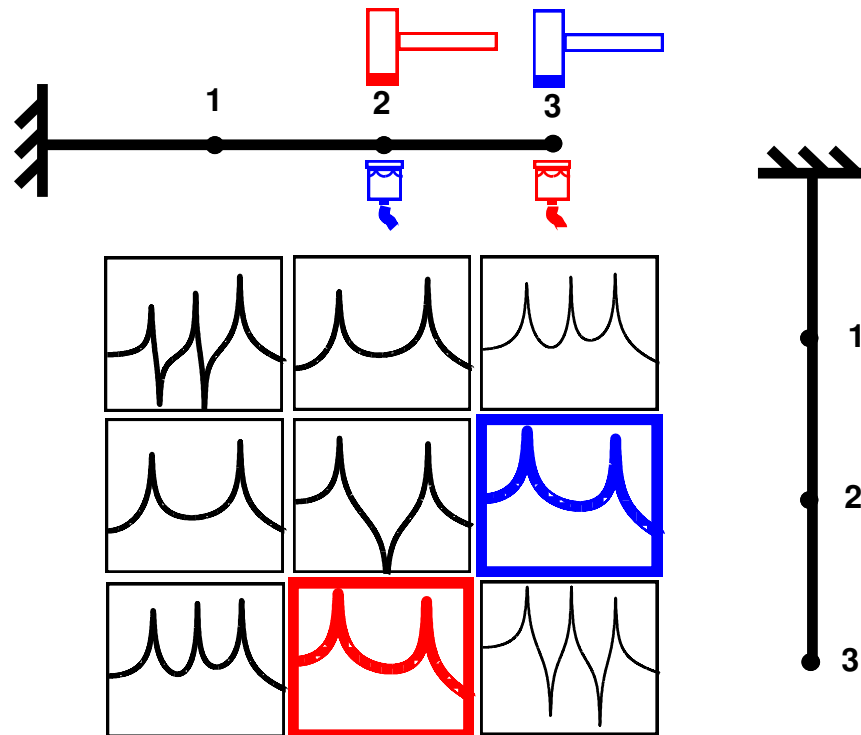

$$\text{Reciprocity} - H_{out/in} = H_{ij}$$

Reciprocity is an underlying necessity for modal theory

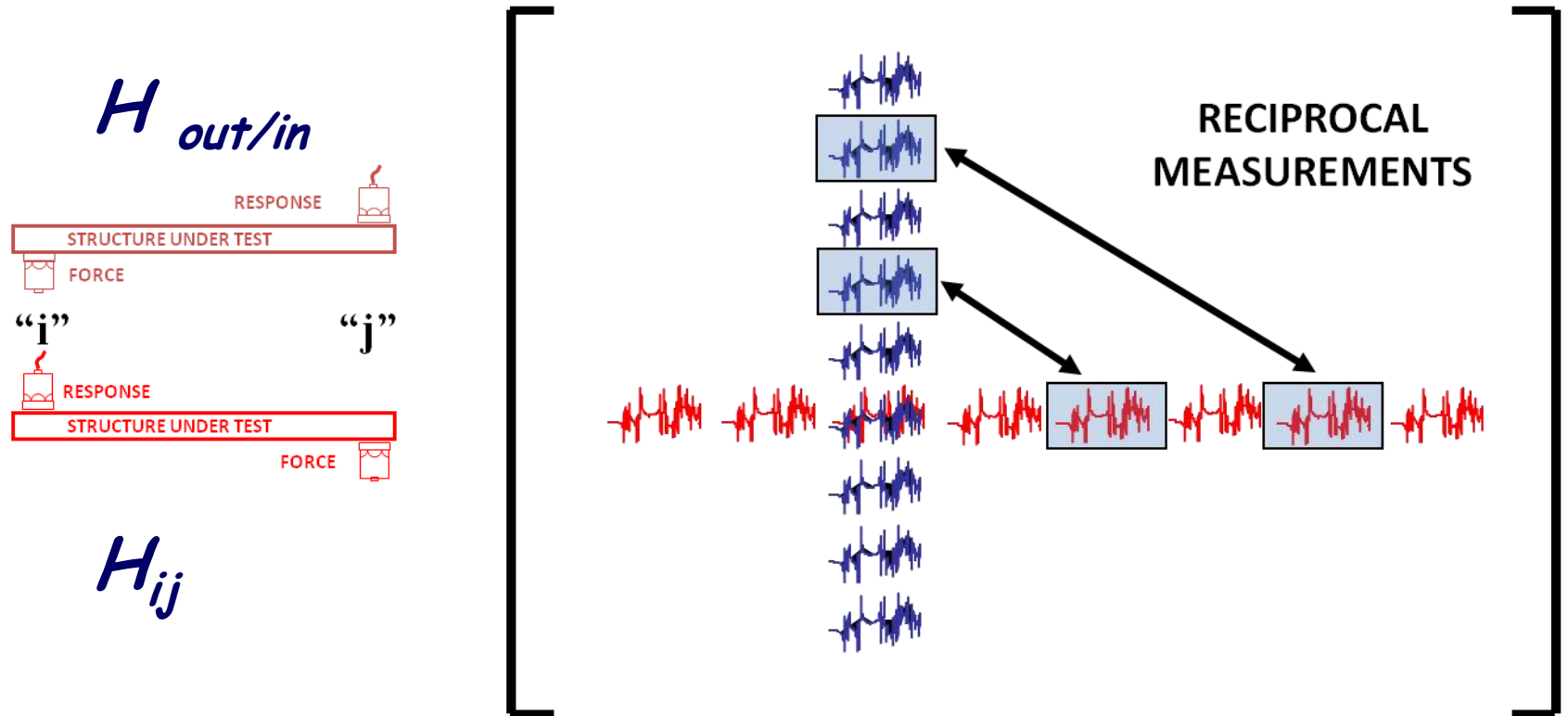

Reciprocity - $H_{out/in} = H_{ij}$ - What can go wrong?

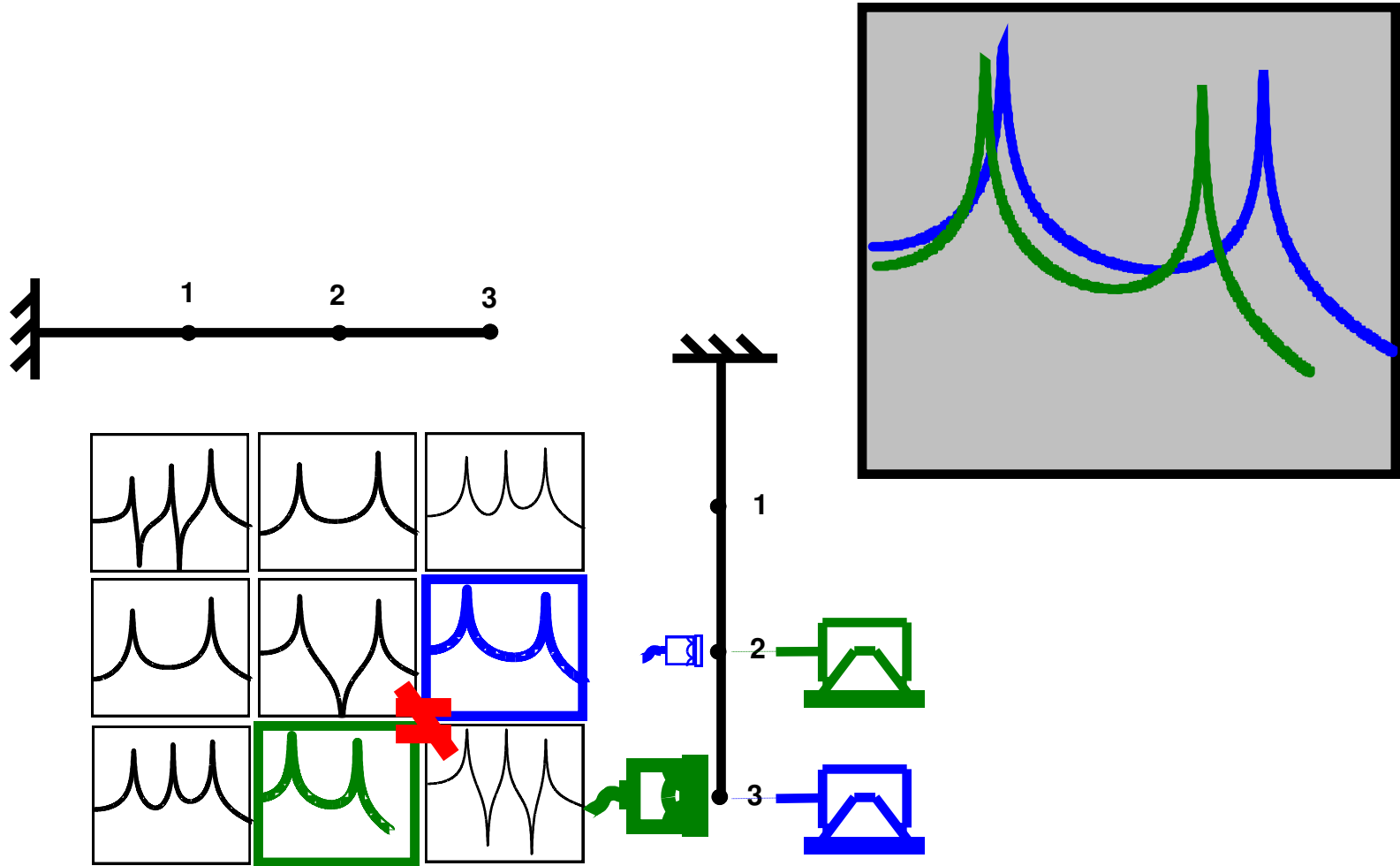

Impact Test - Multiple Reference Impact Test

Either a row or column of the FRF matrix is needed to estimate mode shapes

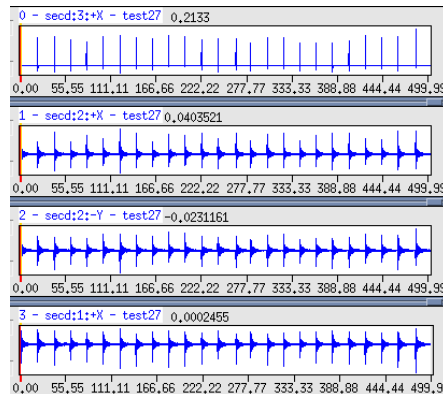
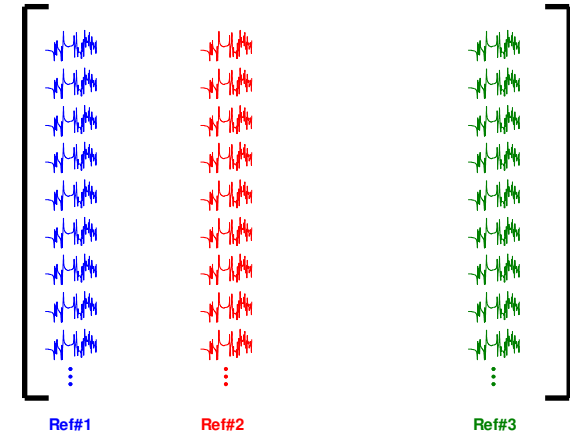
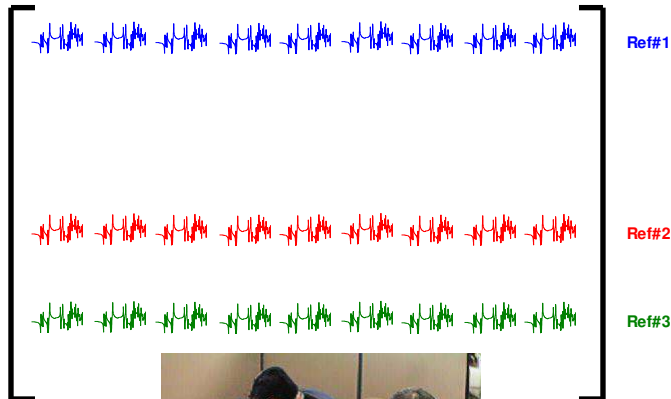

Shaker Test vs. Impact Test - What is the difference?

Typical Shaker Test

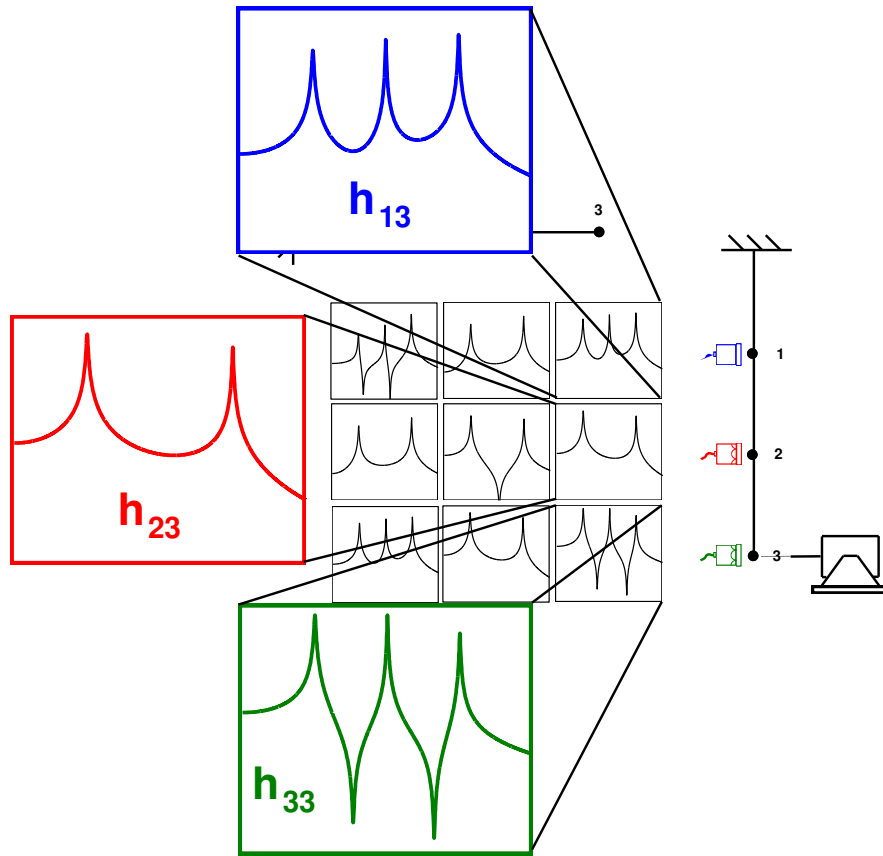

Typical Impact Test

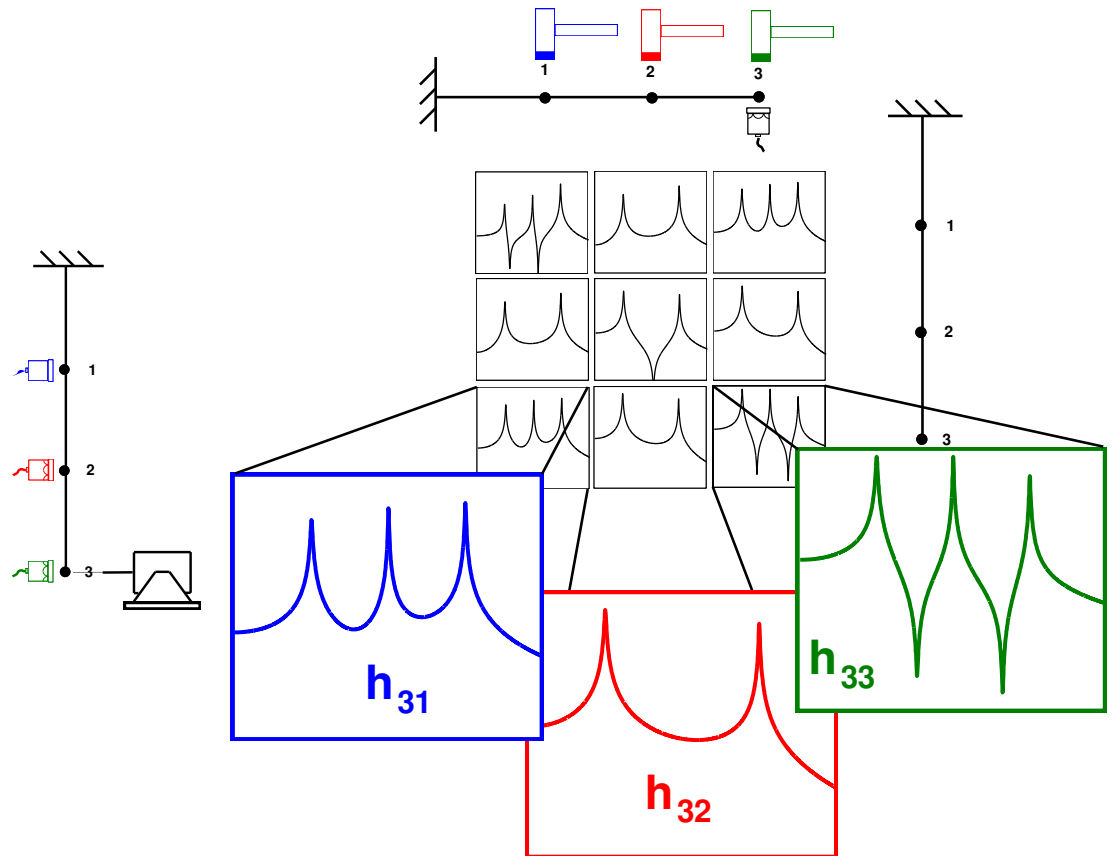

Measurement Definitions

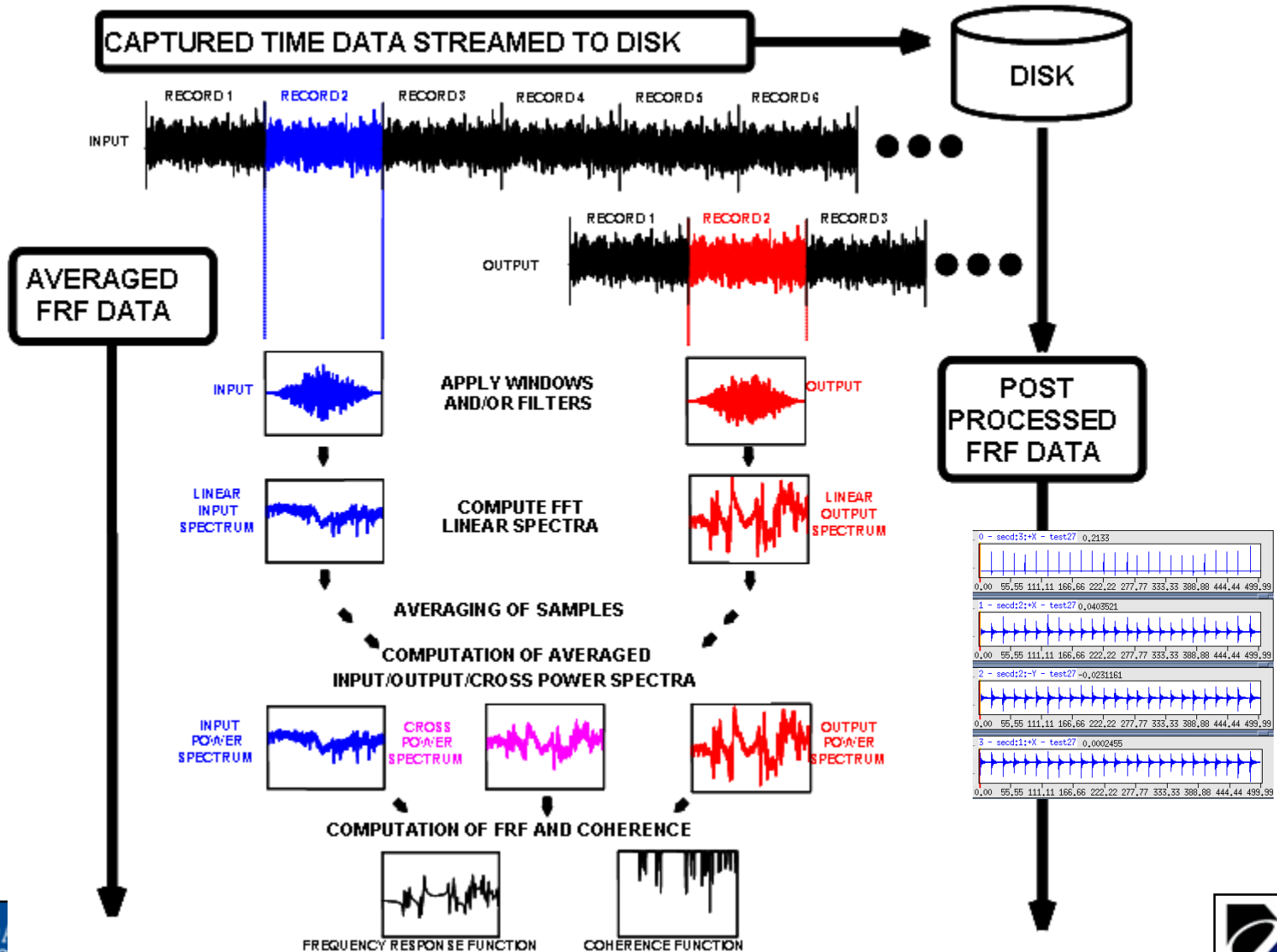

FRF from Impact or Shaker Data

Impact Data

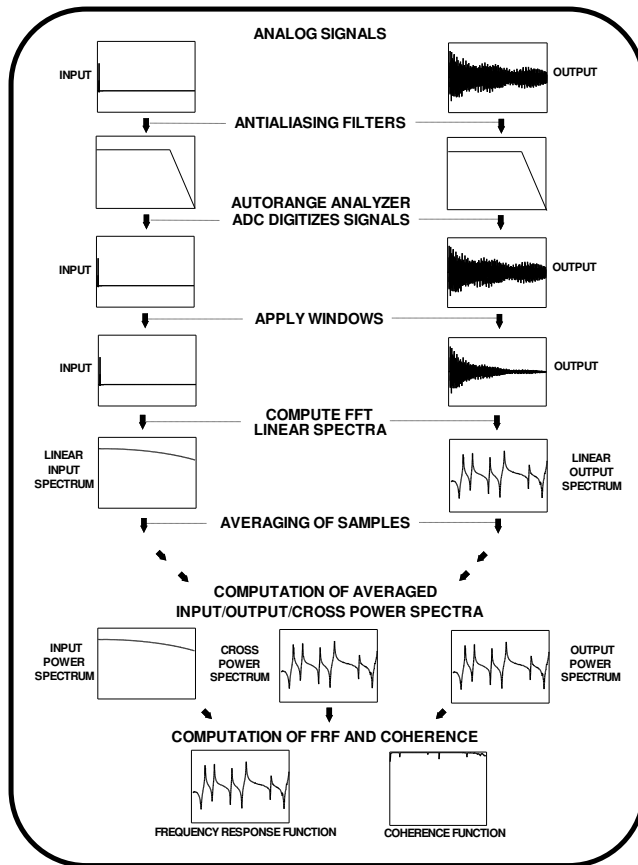

Shaker Data

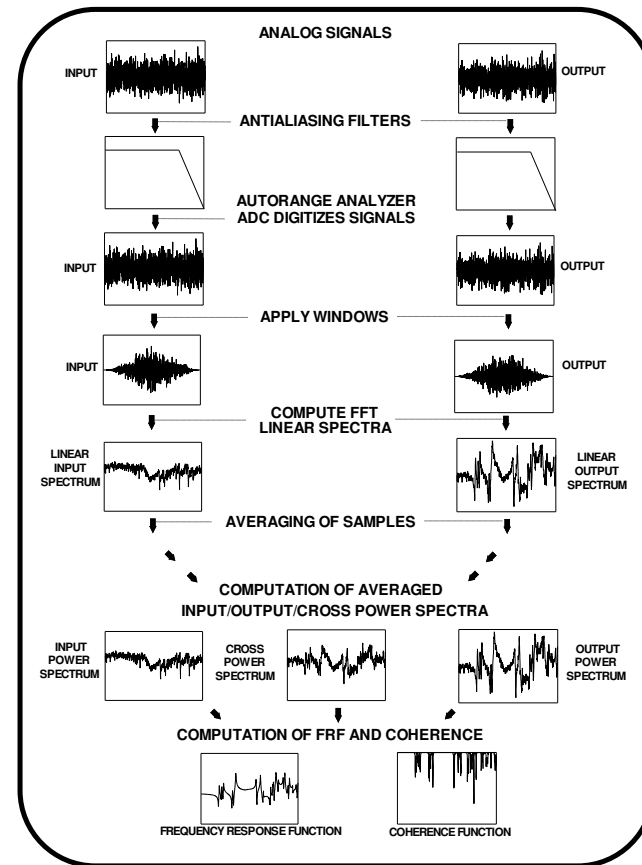

Things to consider

FFT Reference vs. Modal Reference - Confusing Nomenclature

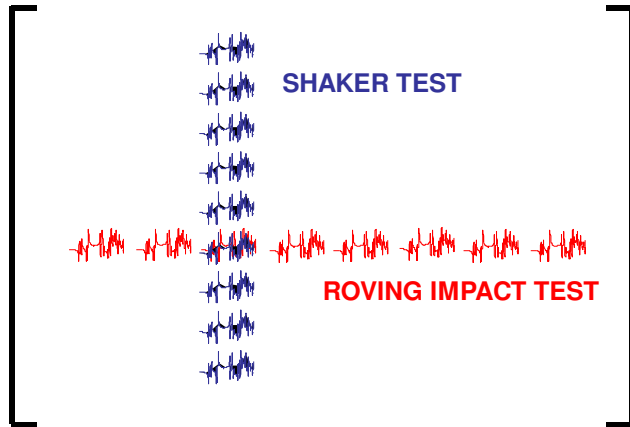

*Reference means different things to different people
That is why there is a "swap"*

HP35665 FFT Analyzer

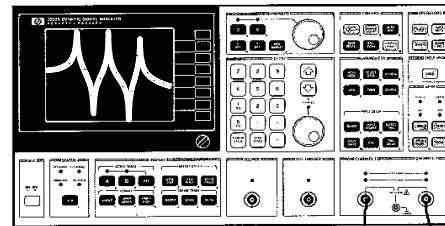

002Z006Z.DAT

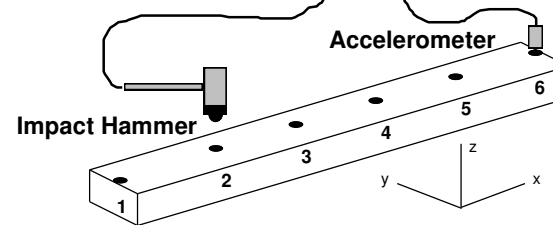
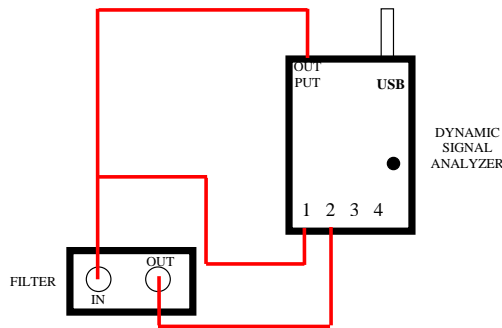

H_{ij}

Why Do Initial Conditions Need to be Zero?

Laplace Domain Equation of Motion

$$(ms^2 + cs + k) x(s) = f(s) + (ms + c)x_0 + m\dot{x}_0$$

Characteristic Portion *Applied Force* *Initial Displacement* *Initial Velocity*

Assuming that initial conditions are zero

$$(ms^2 + cs + k) x(s) = f(s)$$

Why Do Initial Conditions Need to be Zero?

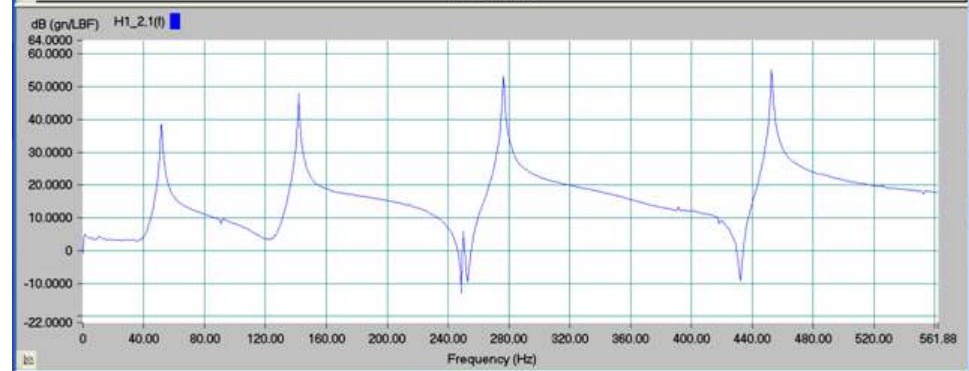
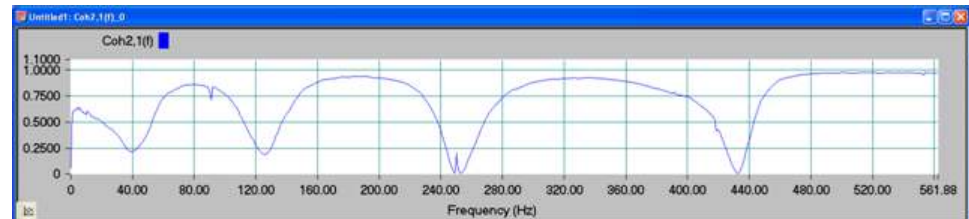
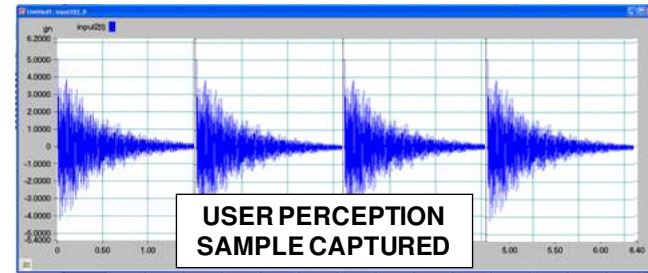
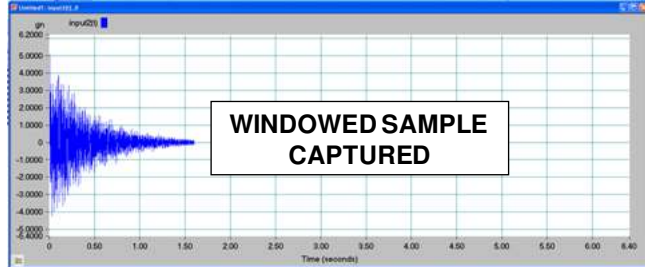
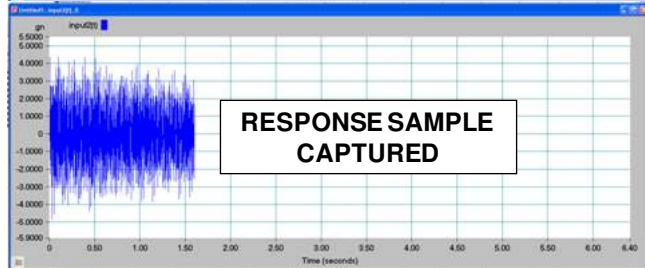
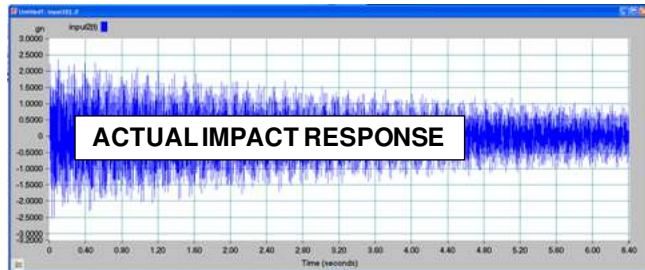

Why Do Initial Conditions Need to be Zero?

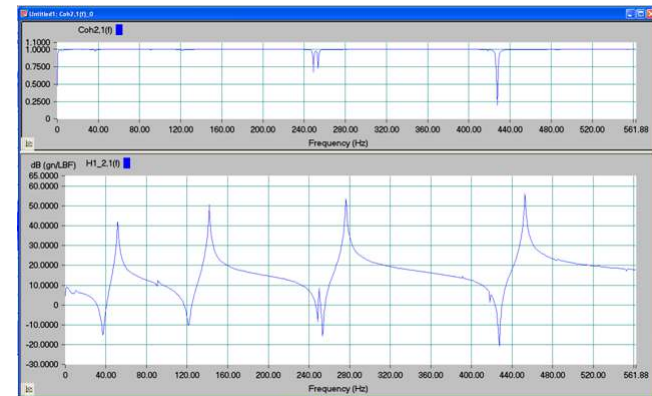
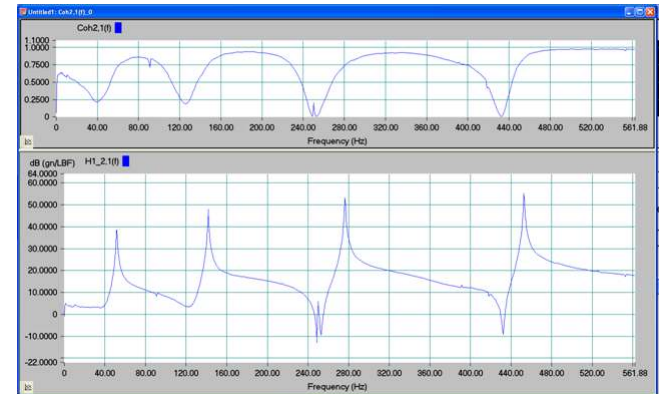
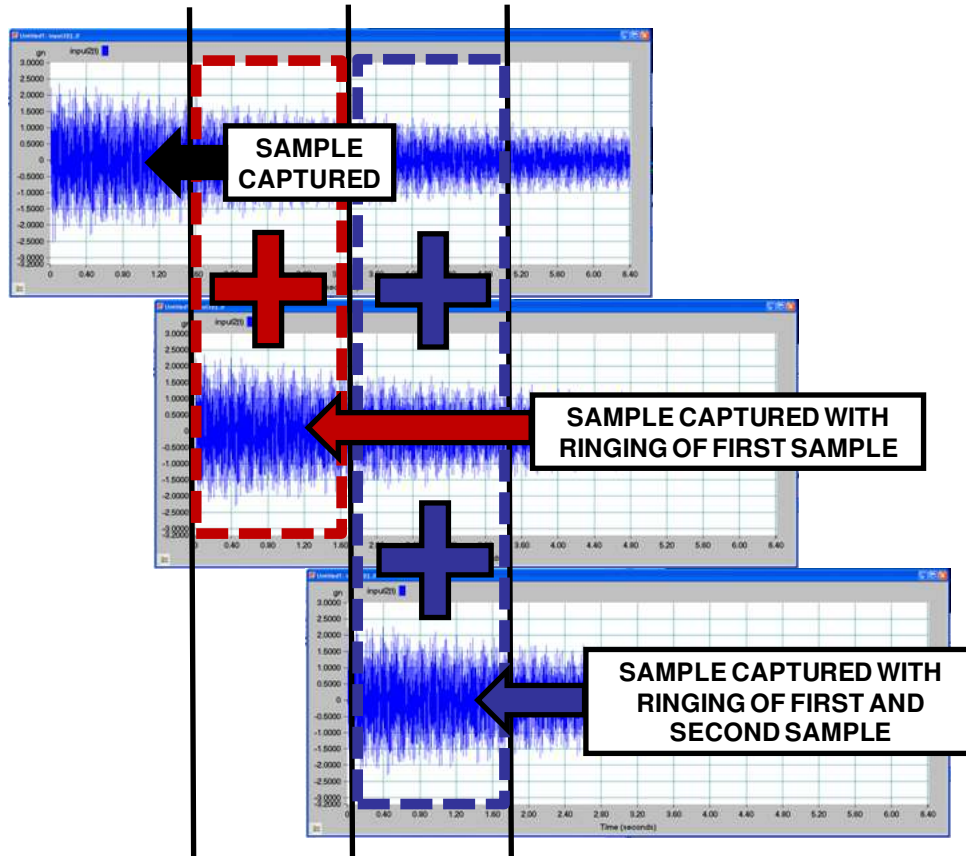

Too Hard a Hammer Tip Can Cause Problems

Energy is imparted to the structure beyond the frequency range of interest and may overload or saturate the response

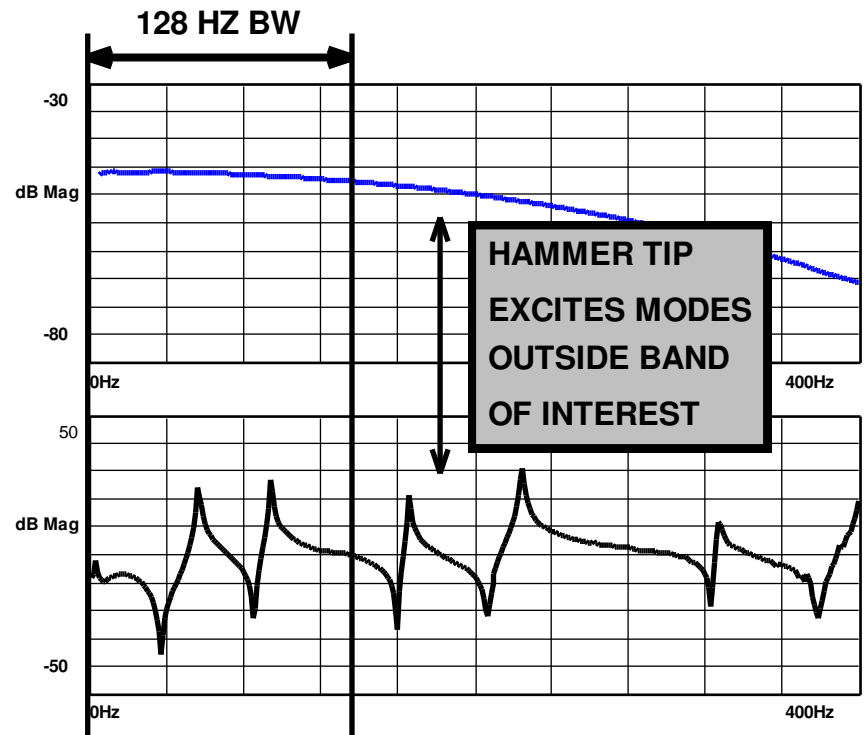
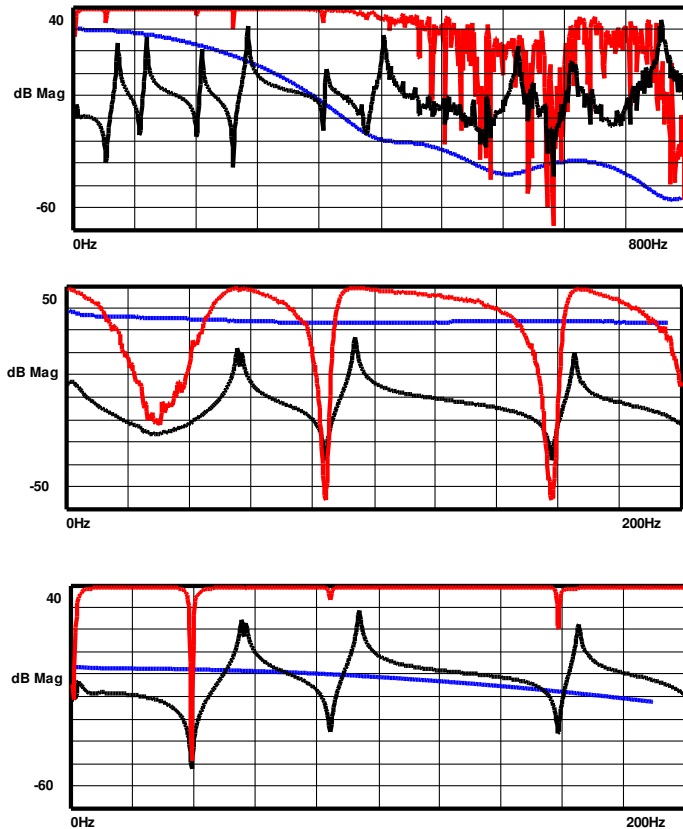

Impact Spectrum Considerations

Selecting the right impact tip to excite the right frequency range is critical to optimizing the measured response

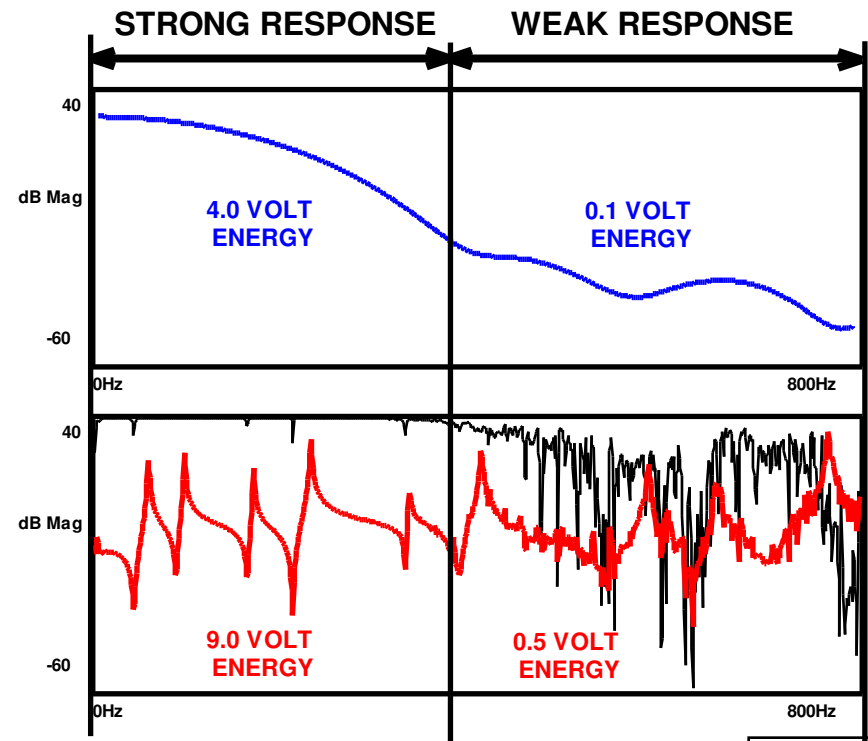
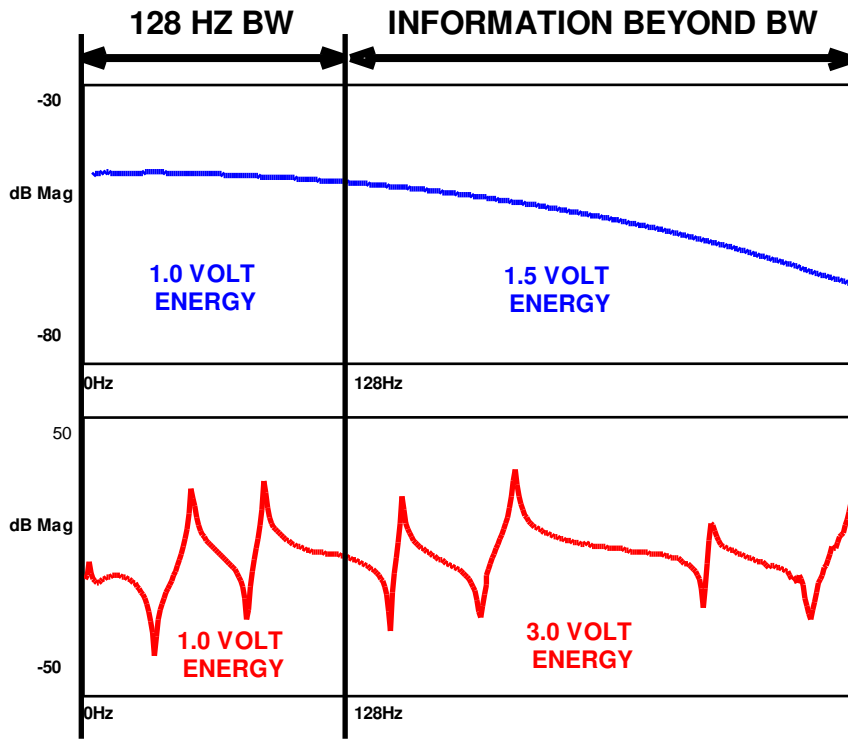

Exponential Window - Can It Be a Problem?

While a window may be ultimately required, never start with the window applied before the raw measurement is reviewed.

How many peaks are observed in the measured FRF.

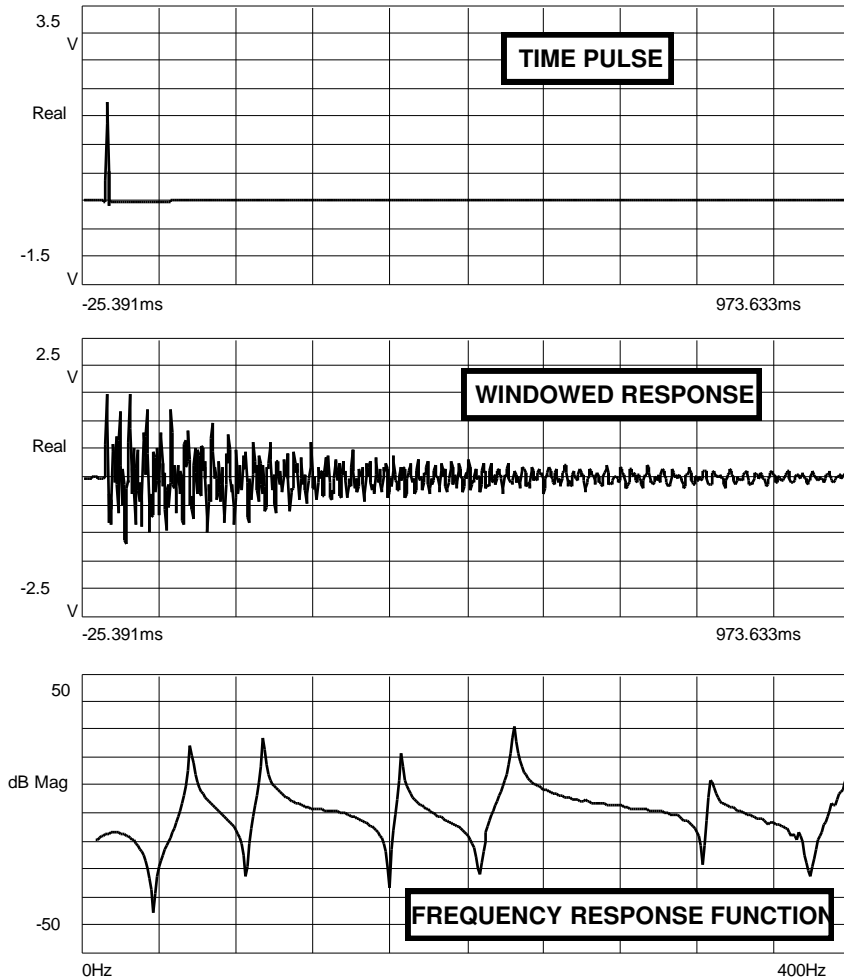

Exponential Window - Can It Be a Problem?

Here is a measurement where a significant amount of damping is applied to the measurement.

How many peaks are observed in the measured FRF.

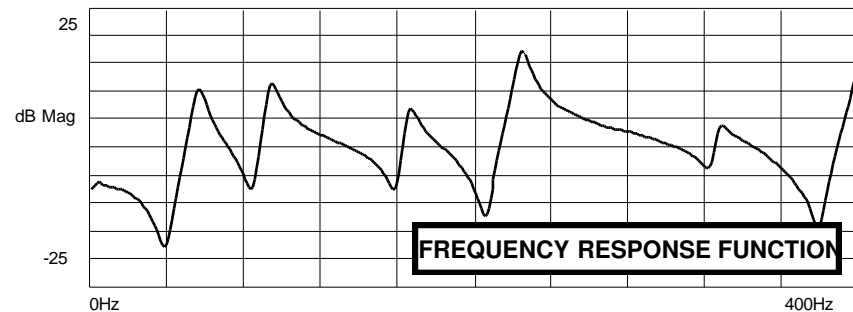
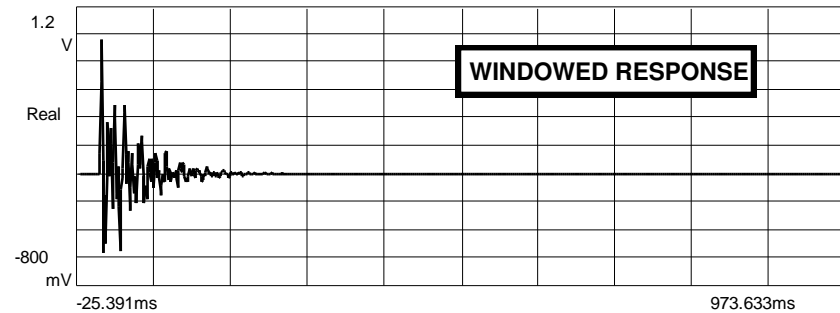
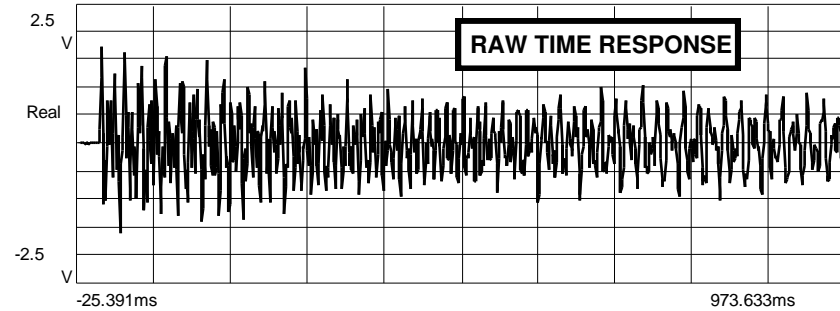

Exponential Window - Can It Be a Problem?

Picking a longer time block allows the response to naturally decay and lessens the need of the exponential window.

How many peaks are observed in the measured FRF.

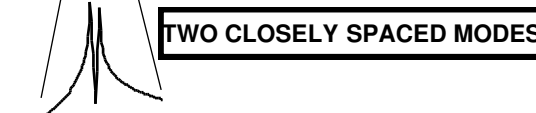
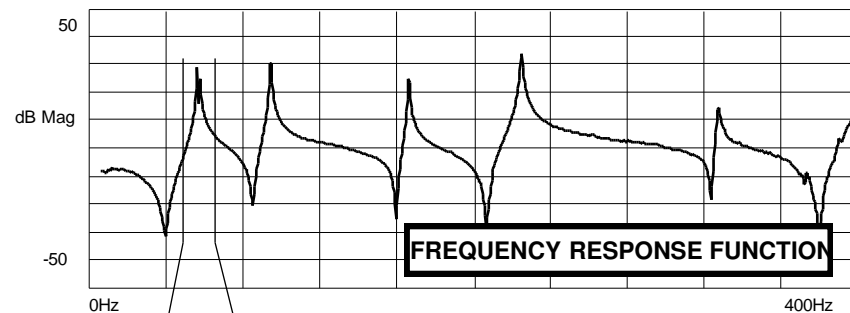
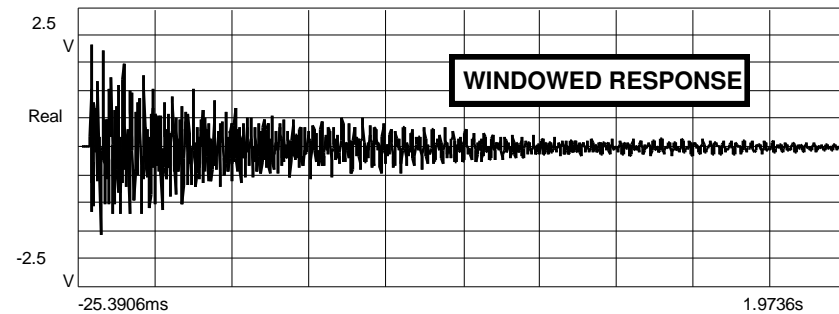
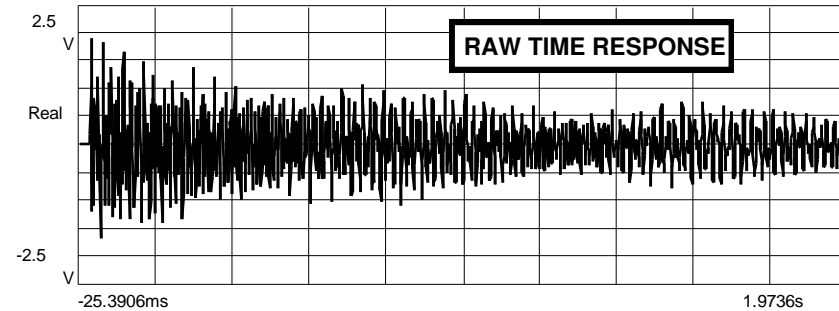

Exponential Window - Can It Be a Problem?

Window should only be applied once it is deemed necessary

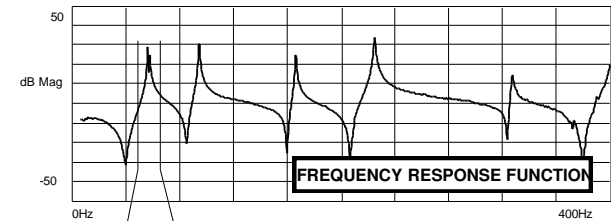
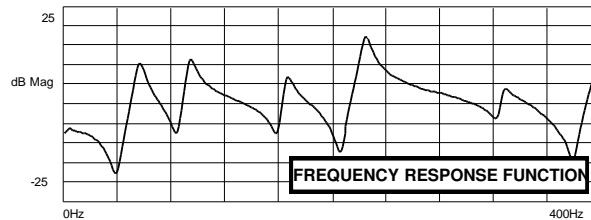
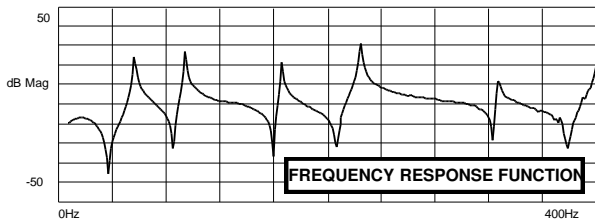
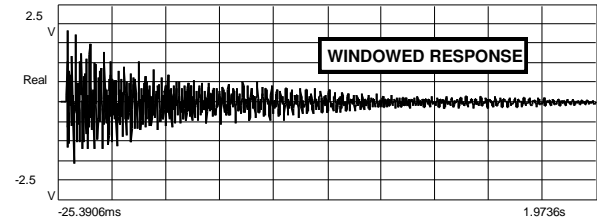
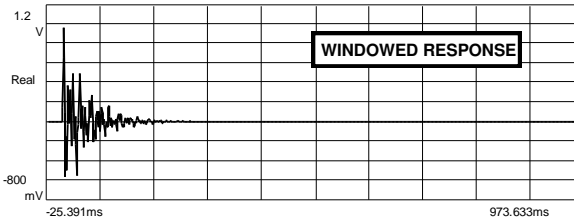
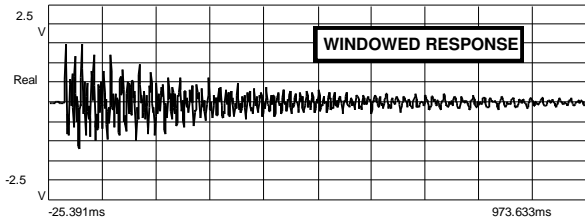
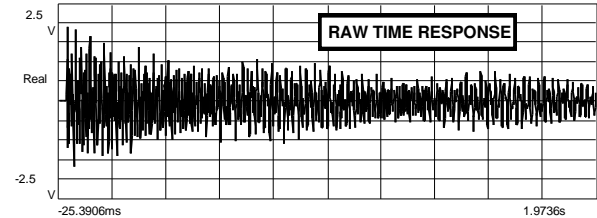
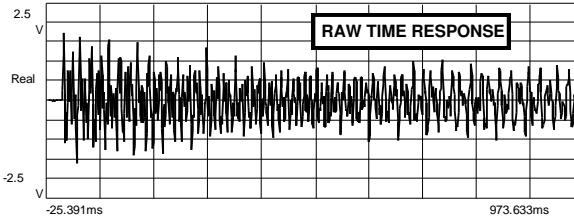
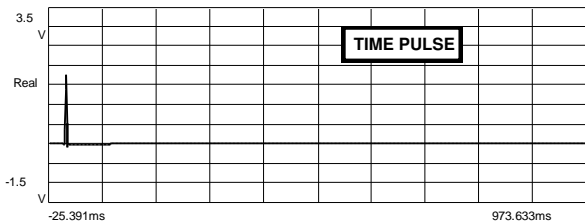

TWO CLOSELY SPACED MODES

Double Impacts - A Problem - Or is it ???

Picking a poor measurement location avoids the double impact but does the measurement look better?

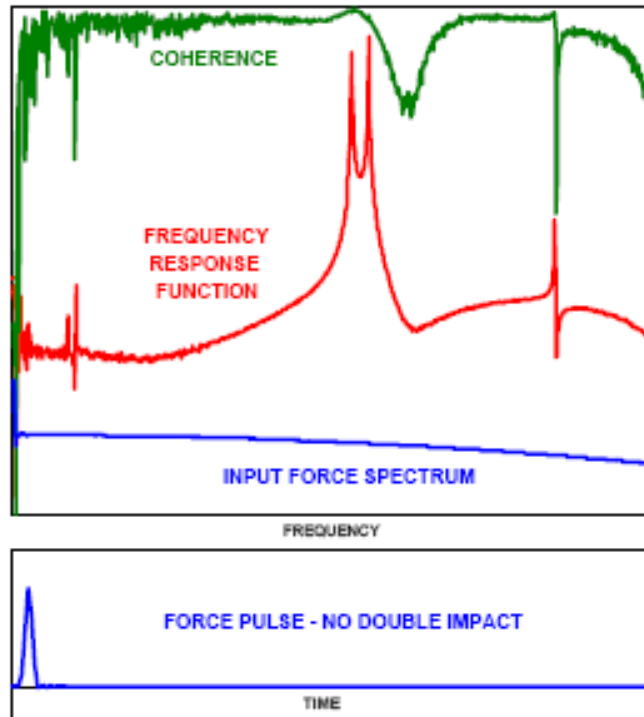

Figure 2 - Measurement with No Double Impact

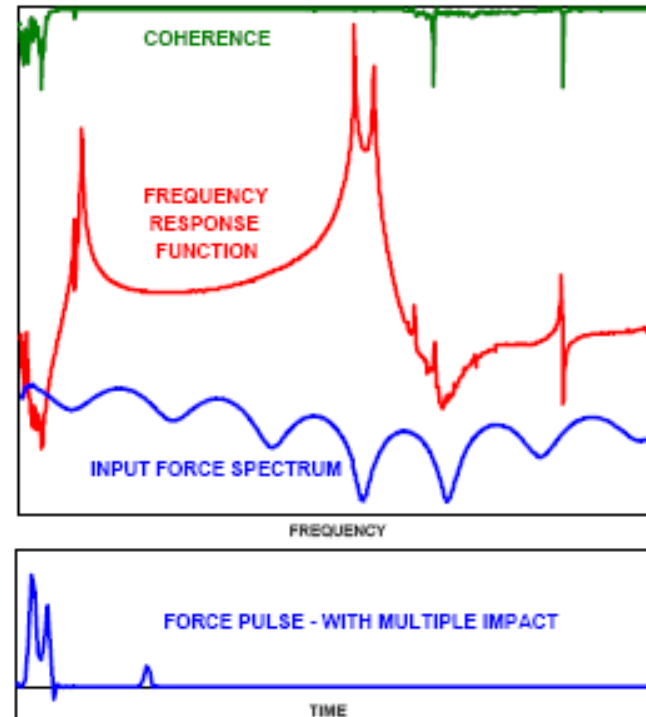
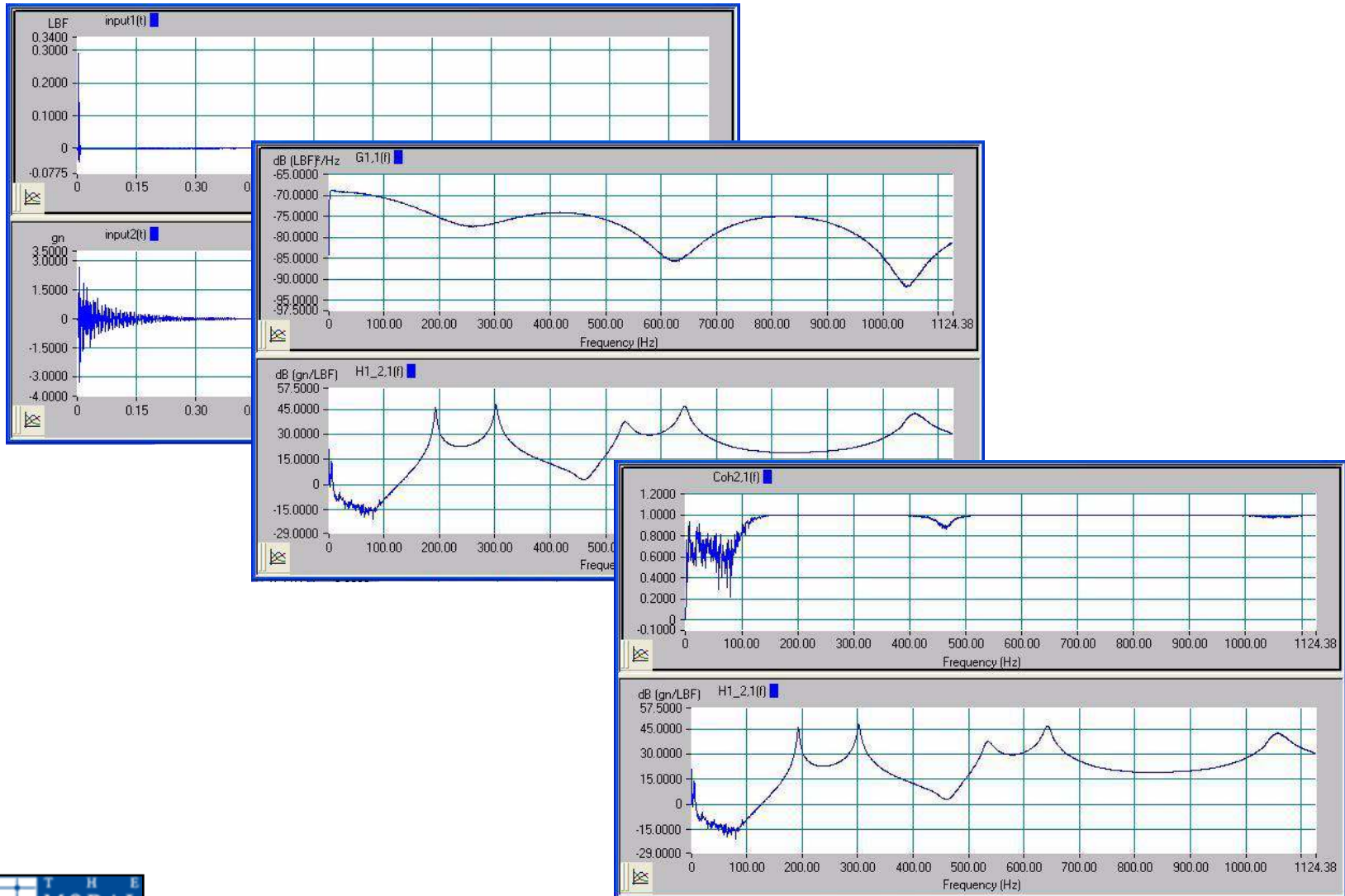
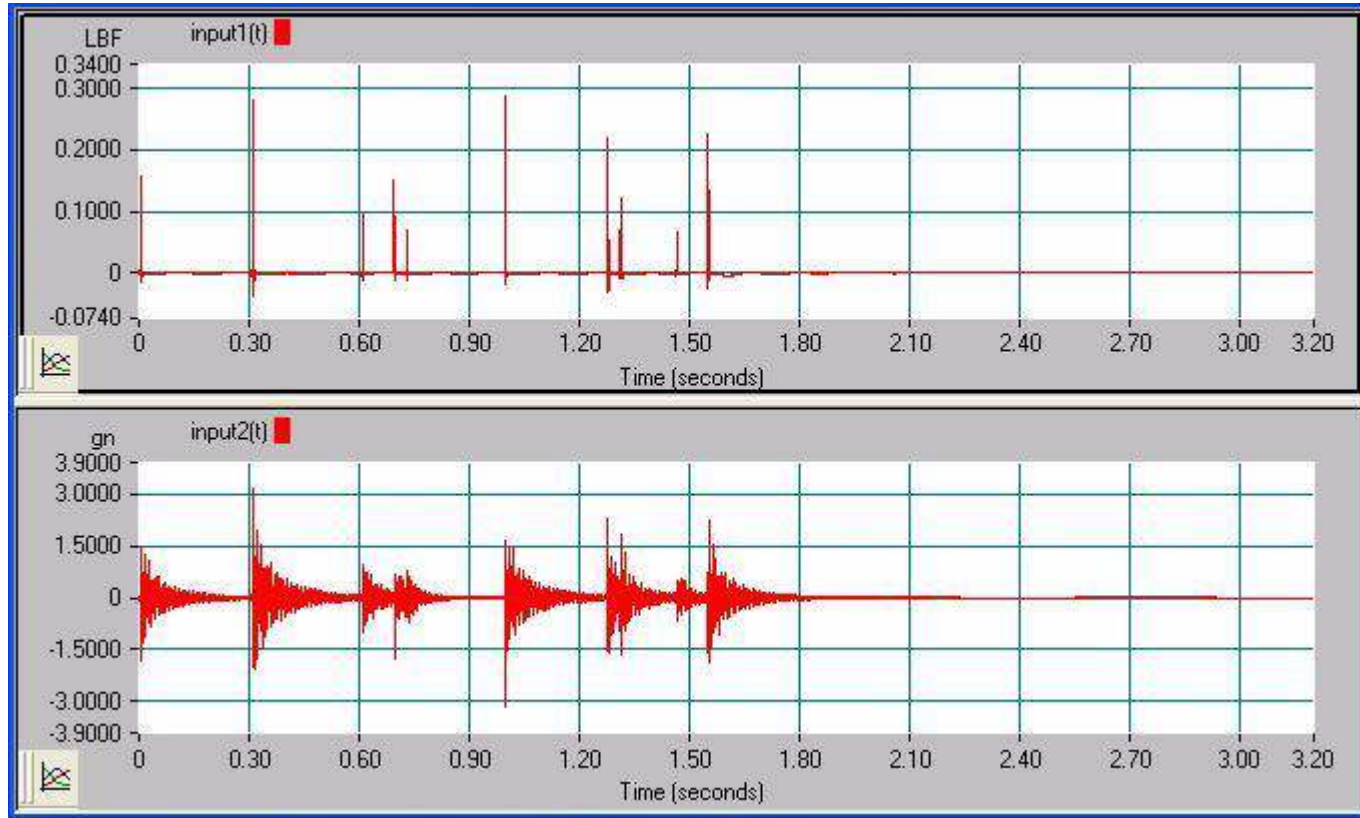

Figure 3 - Measurement with Multiple Impacts

Double Impact - Common Difficulty



If you can't avoid double impact - what about multiple impacts



So if you can't avoid double impact - what about multiple

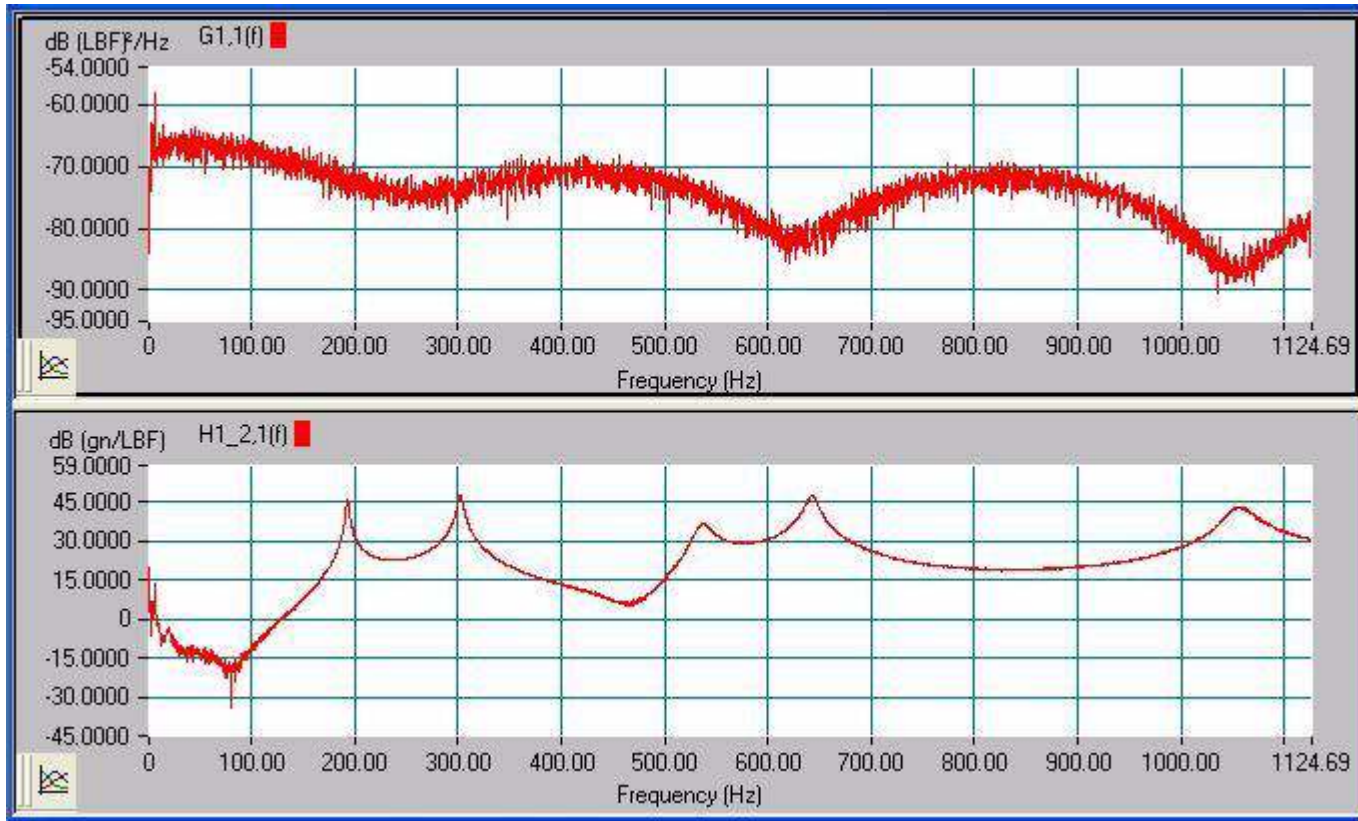

So if you can't avoid double impact - what about multiple

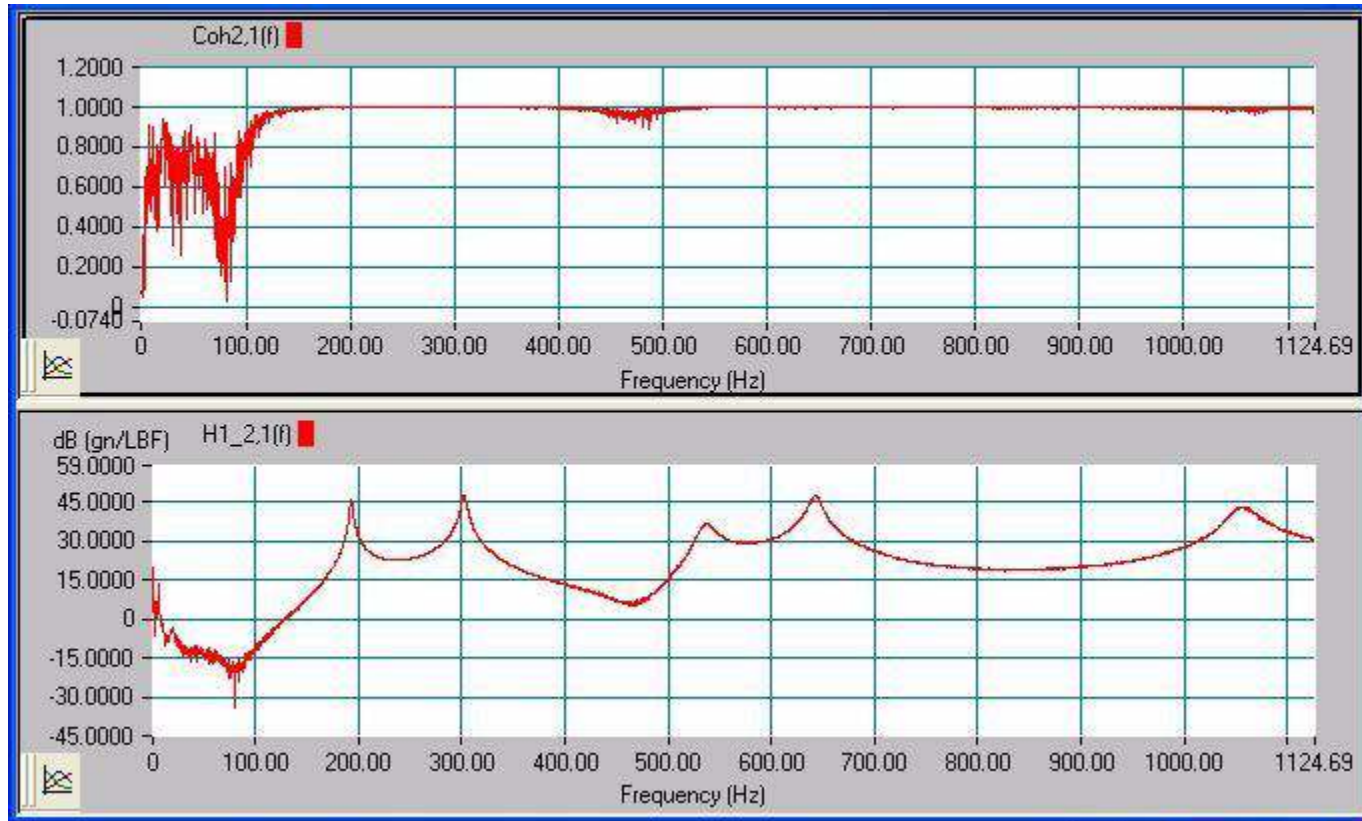

Multiple Impacts - A Possibility !!!

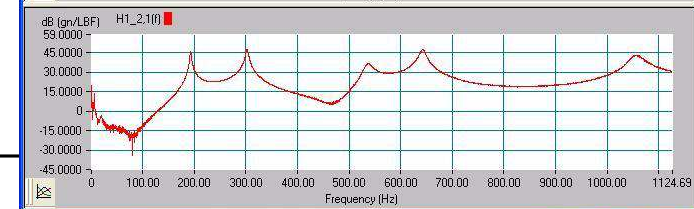
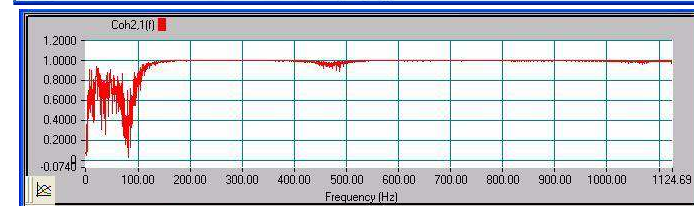
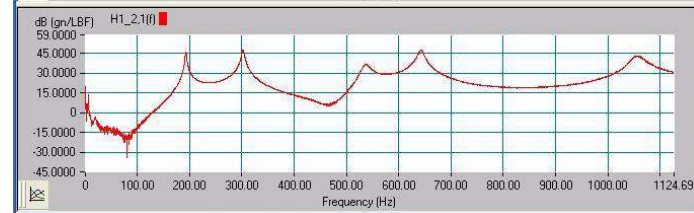
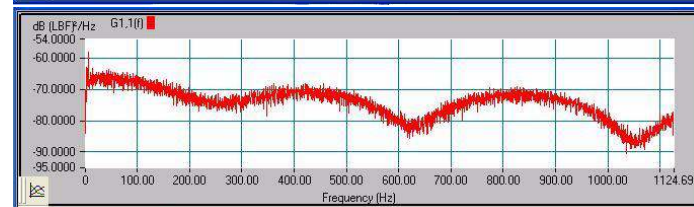
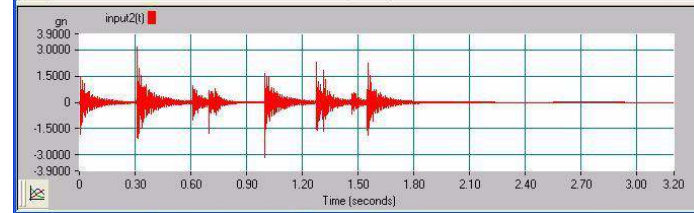
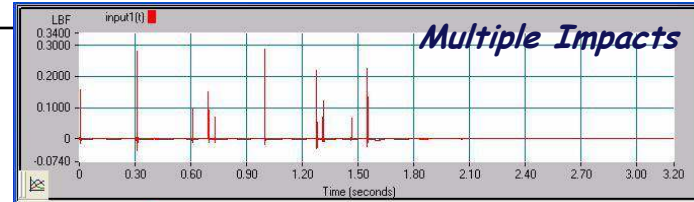
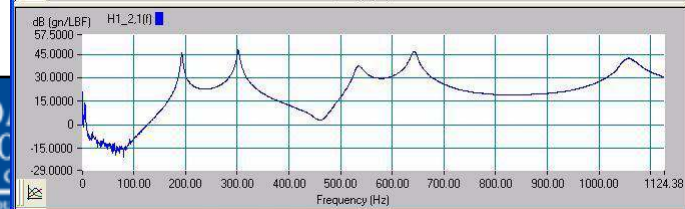
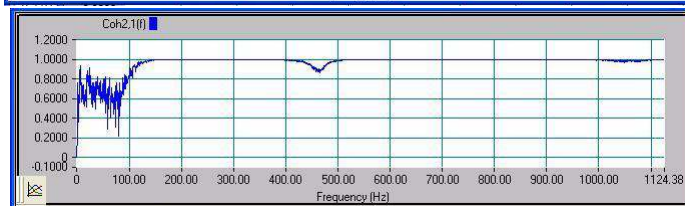
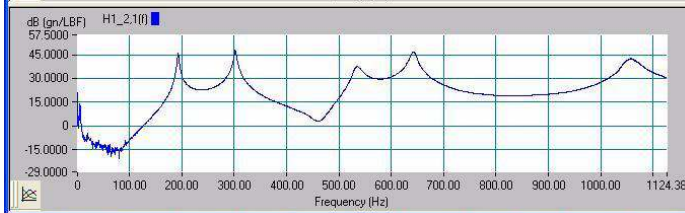
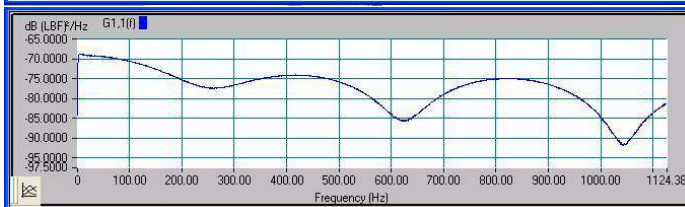
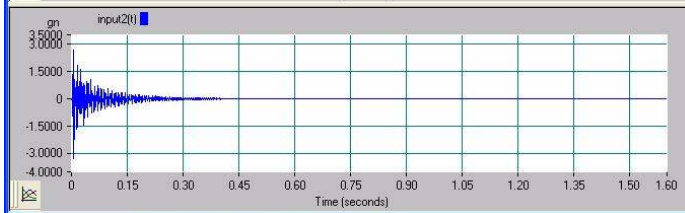
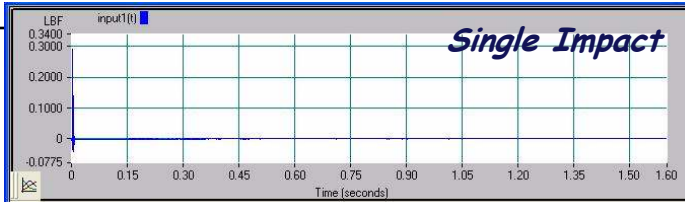

Should I look at all the measurements ?

This measurement looks fine - but do all look this good?

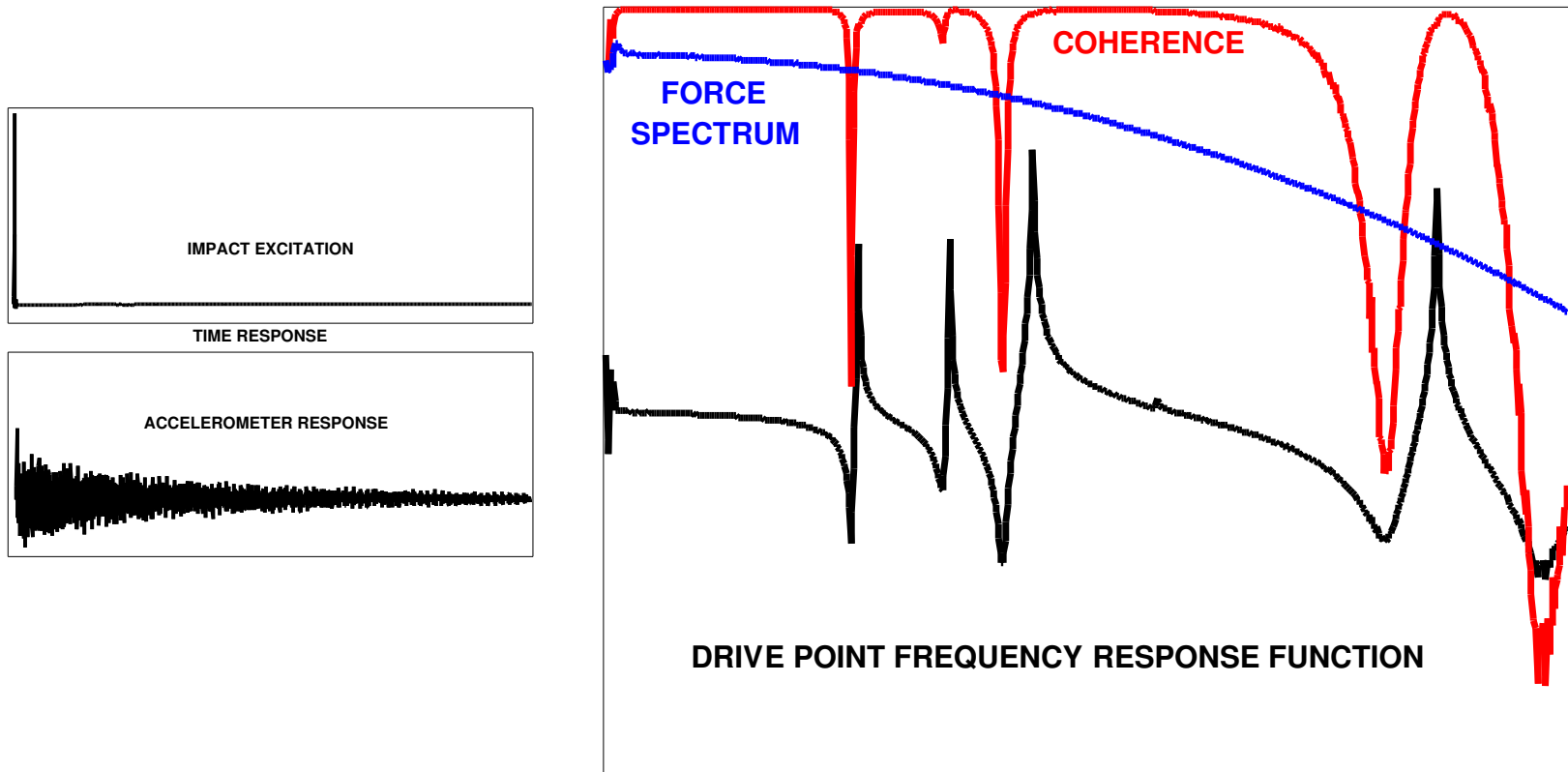

Should I look at all the measurements ?

Here's a measurement that doesn't look as good as the rest.

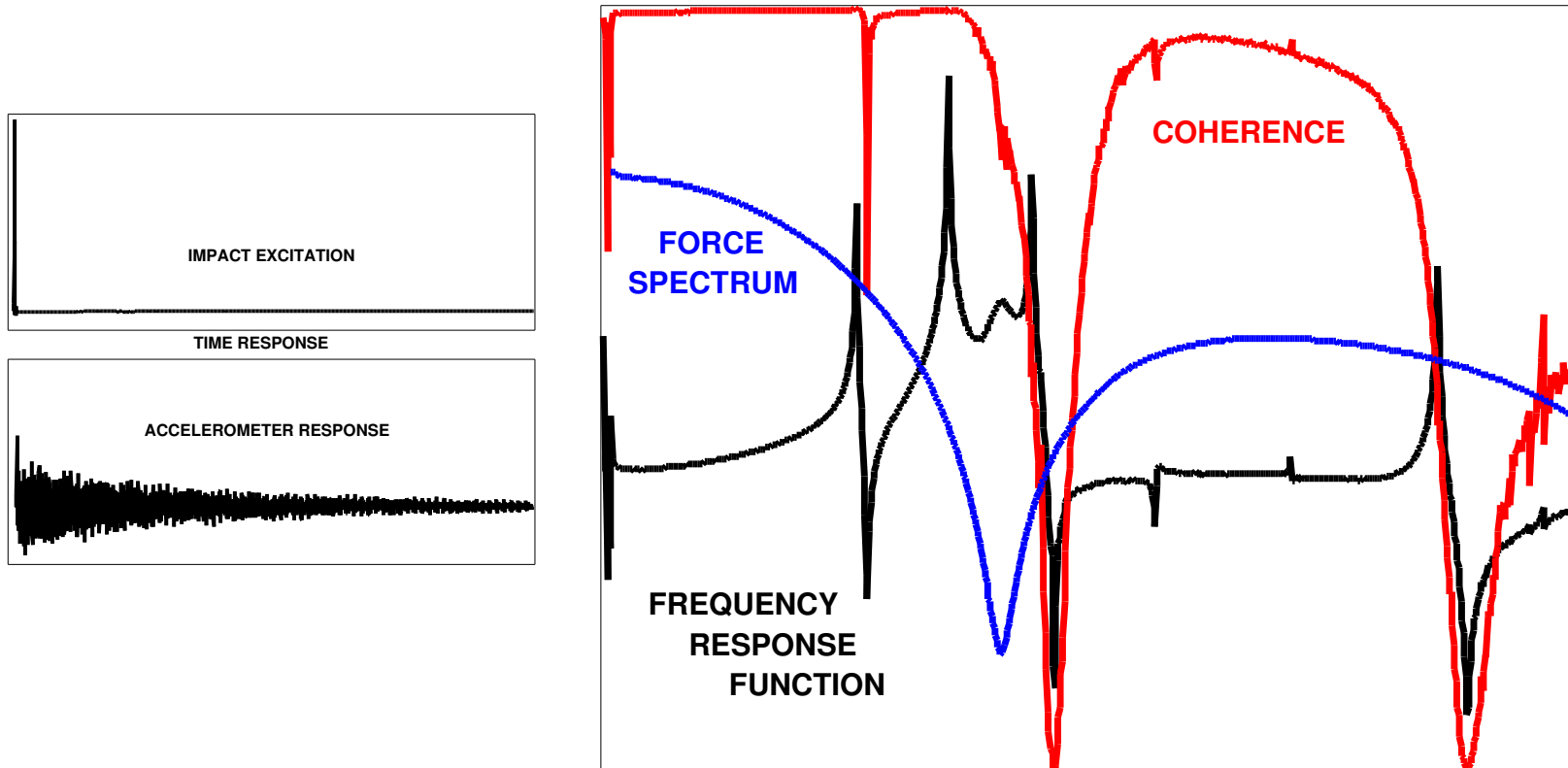

All measurements should be reviewed

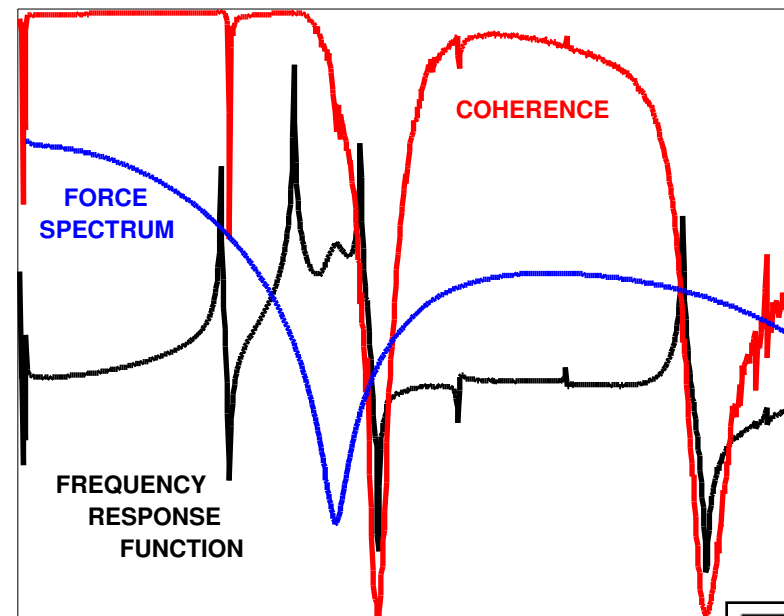
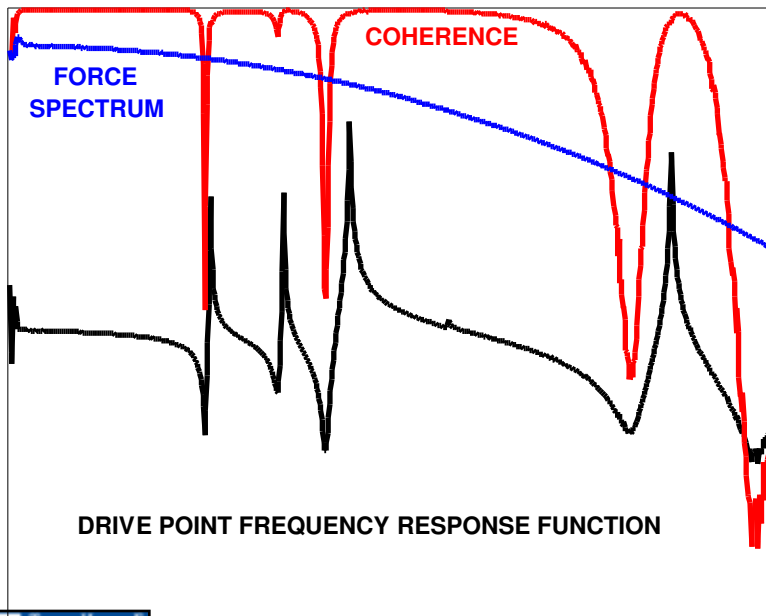
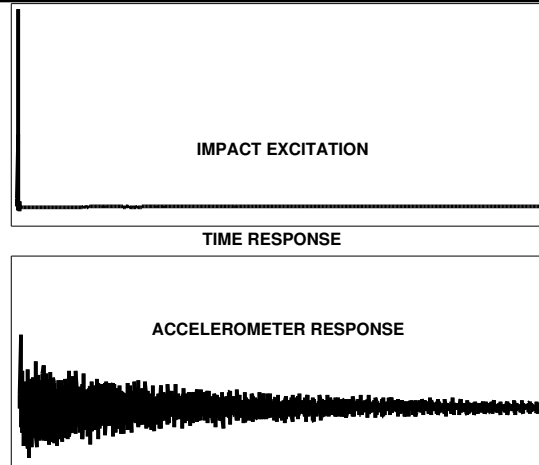

Filter Ring

Sometimes there can be some ringing on the impact input.

This is referred to as "filter ring"

Depending on the bandwidth and impact spectrum, this may or may not appear on the measured data

The following slide shows the effects of this phenomena

Filter Ring

400 HZ BANDWIDTH SETTING

1600 HZ BANDWIDTH SETTING

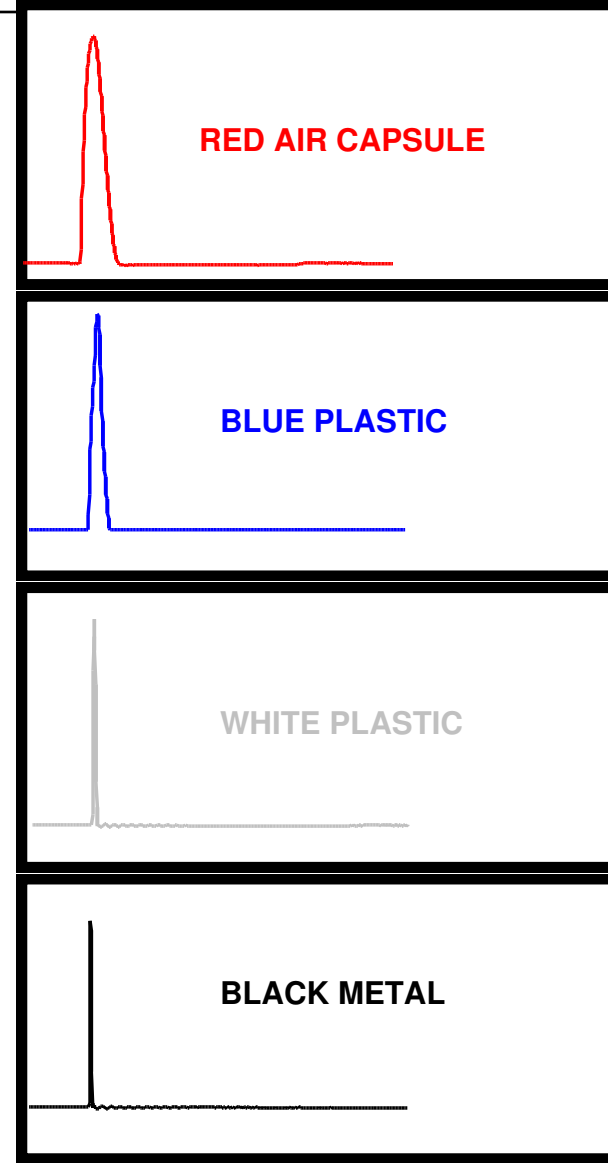
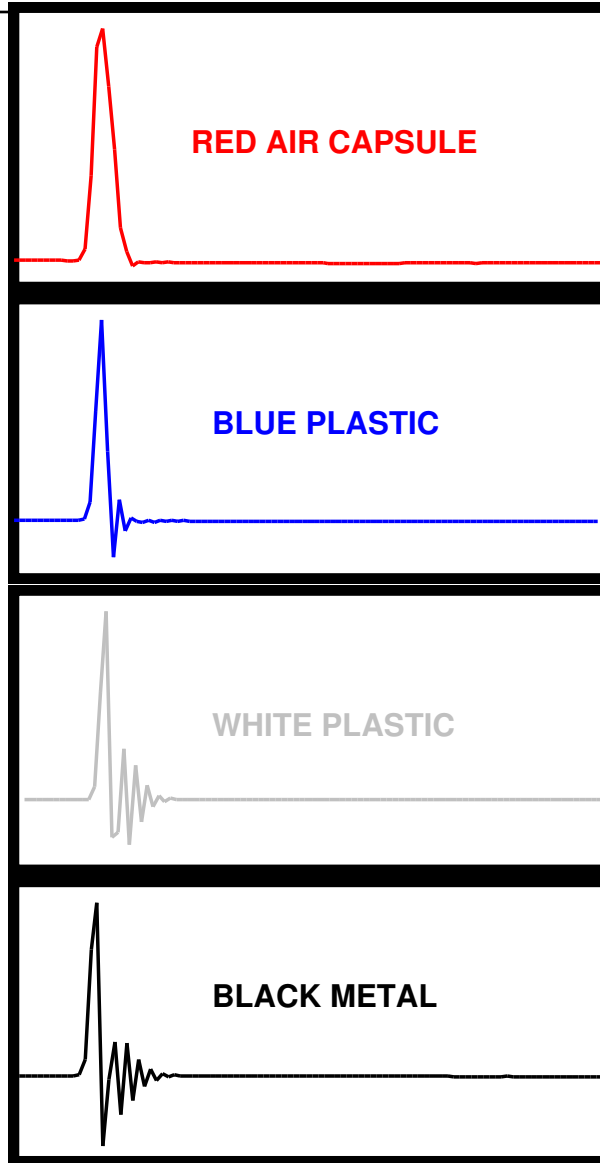

2KHz excitation for 500 Hz BW

*Sometimes data may be collected for multiple purposes.
One group wants data to 500Hz and another needs 2KHz.*

*Can a test be constructed with one set of accelerometers to
acquire the data for both test ranges?*

*Difficult to achieve unless you have infinite resolution and
infinite spectral resolution.*



2KHz excitation for 500 Hz BW

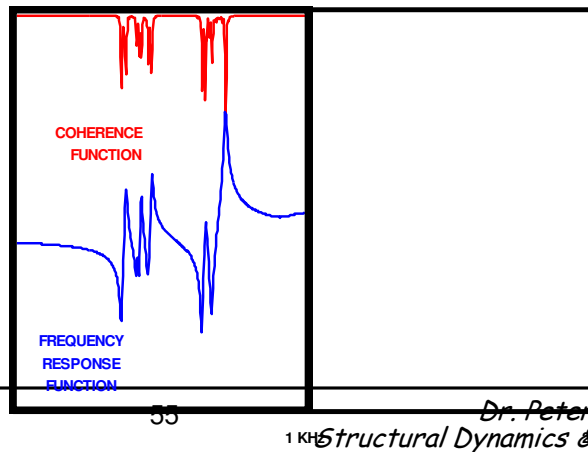
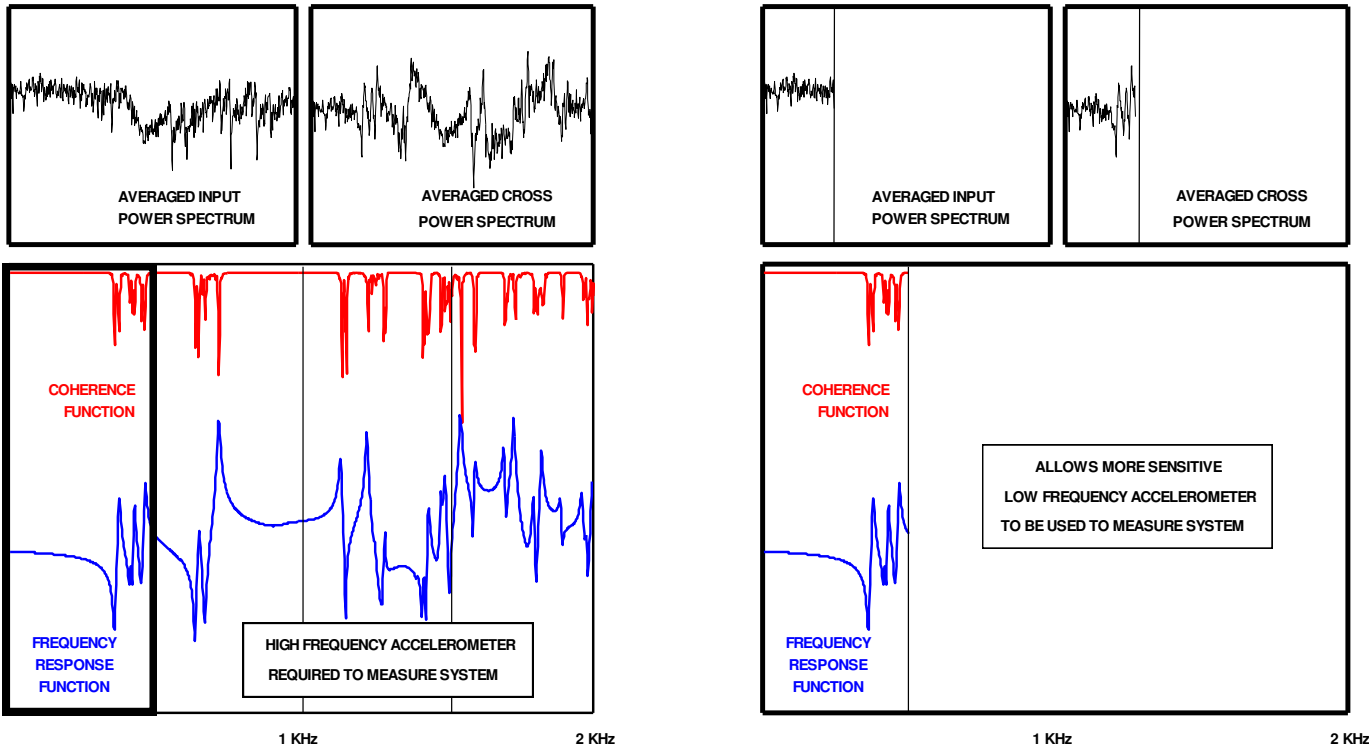

Impact Location Effects - Skewed and Same Point

When performing impact testing it is important to impact the same point in the same direction for all averages.



One case will be presented to show the effects of having a skewed input, that is different for each average of the measurement.

Another case is presented to show the effects of impacting close to the same point, but not exactly the same point, for all averages.



Impact Location Effects

Notice that the coherence for the skewed input is not as good as the measurement with consistent input excitation

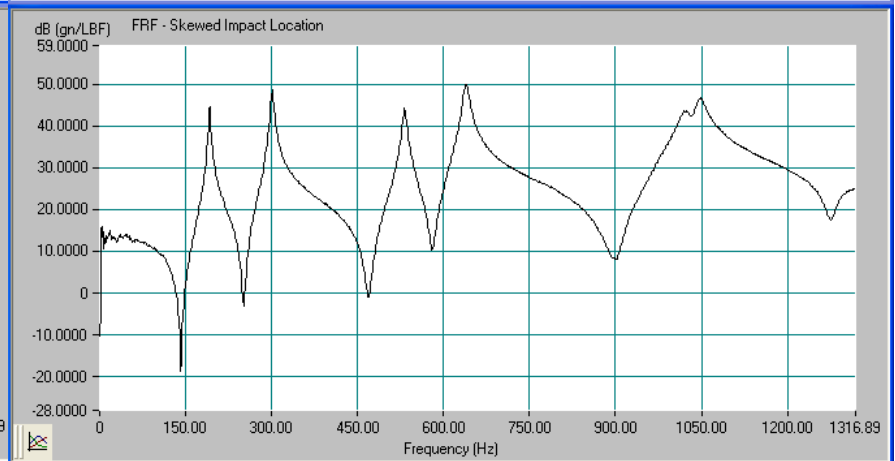
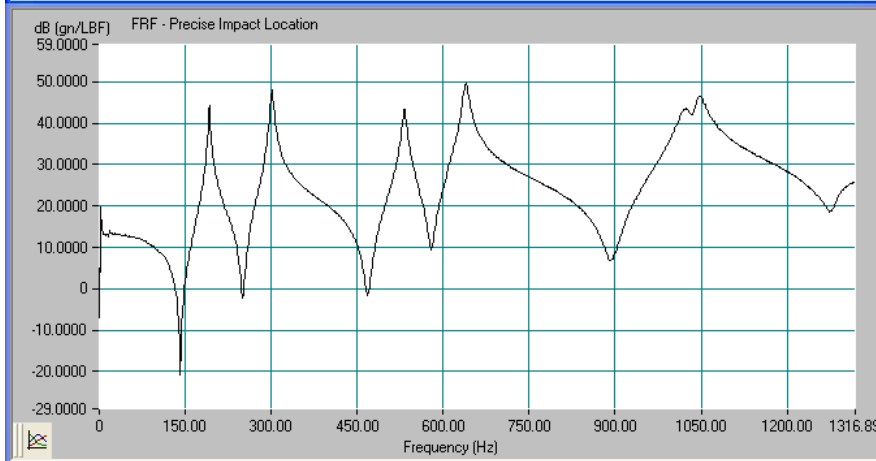
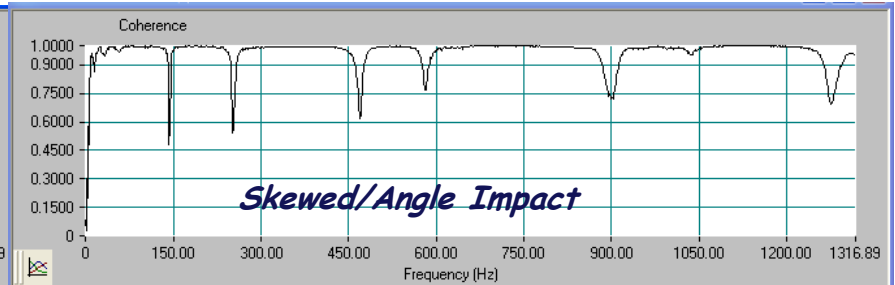
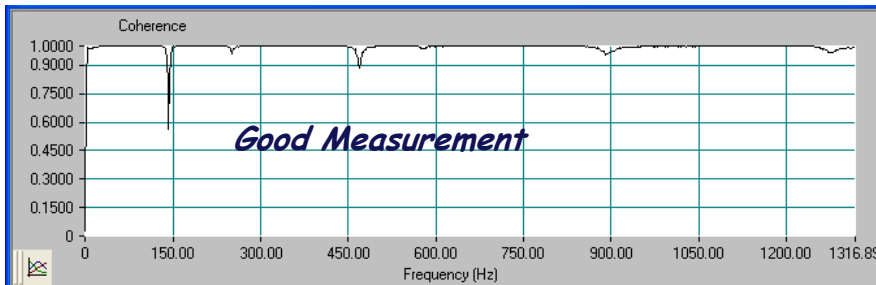

Impact Location Effects

Notice that the coherence for the impact around point is not as good as the measurement with consistent input excitation

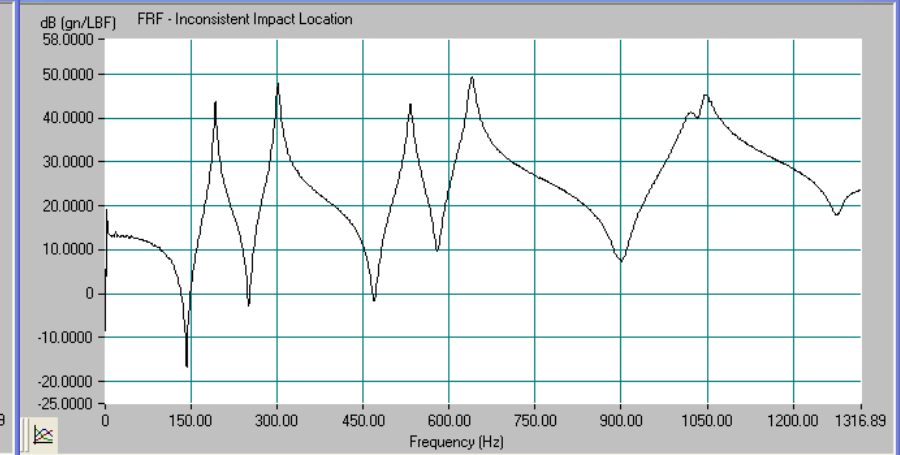
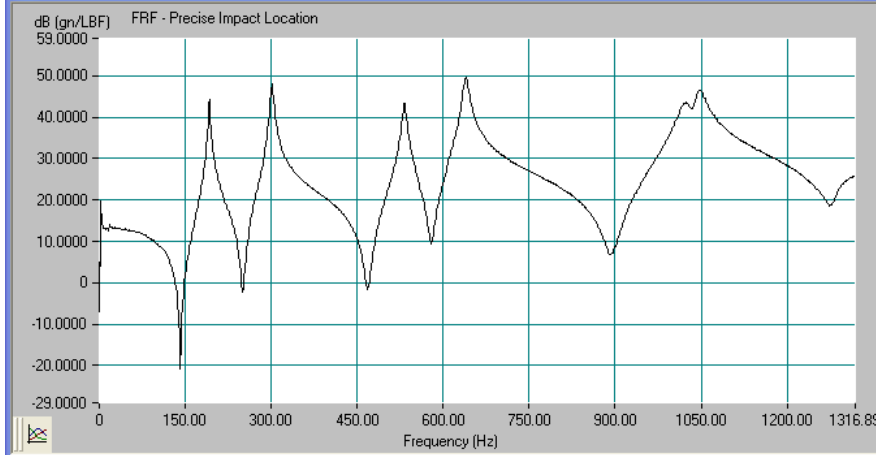
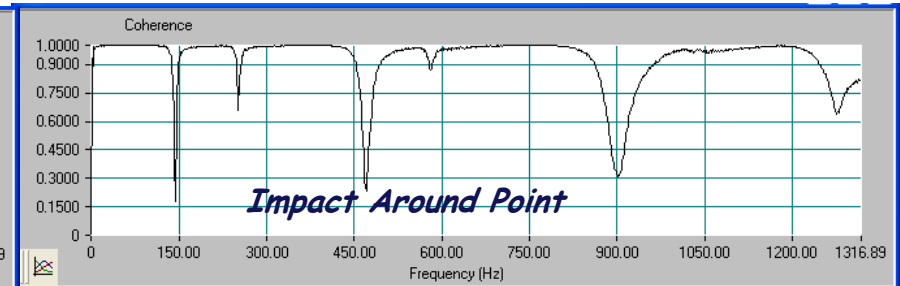
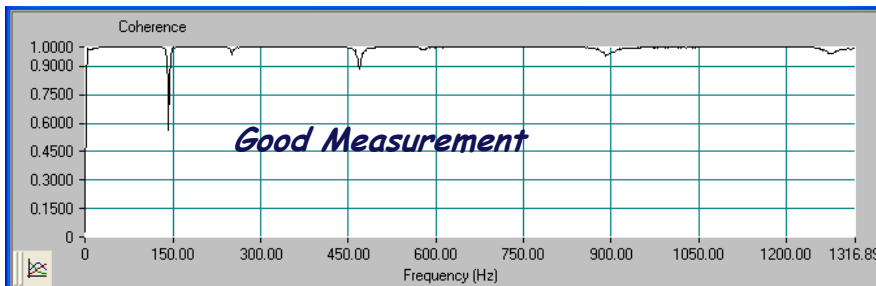

Control the Location of Excitation

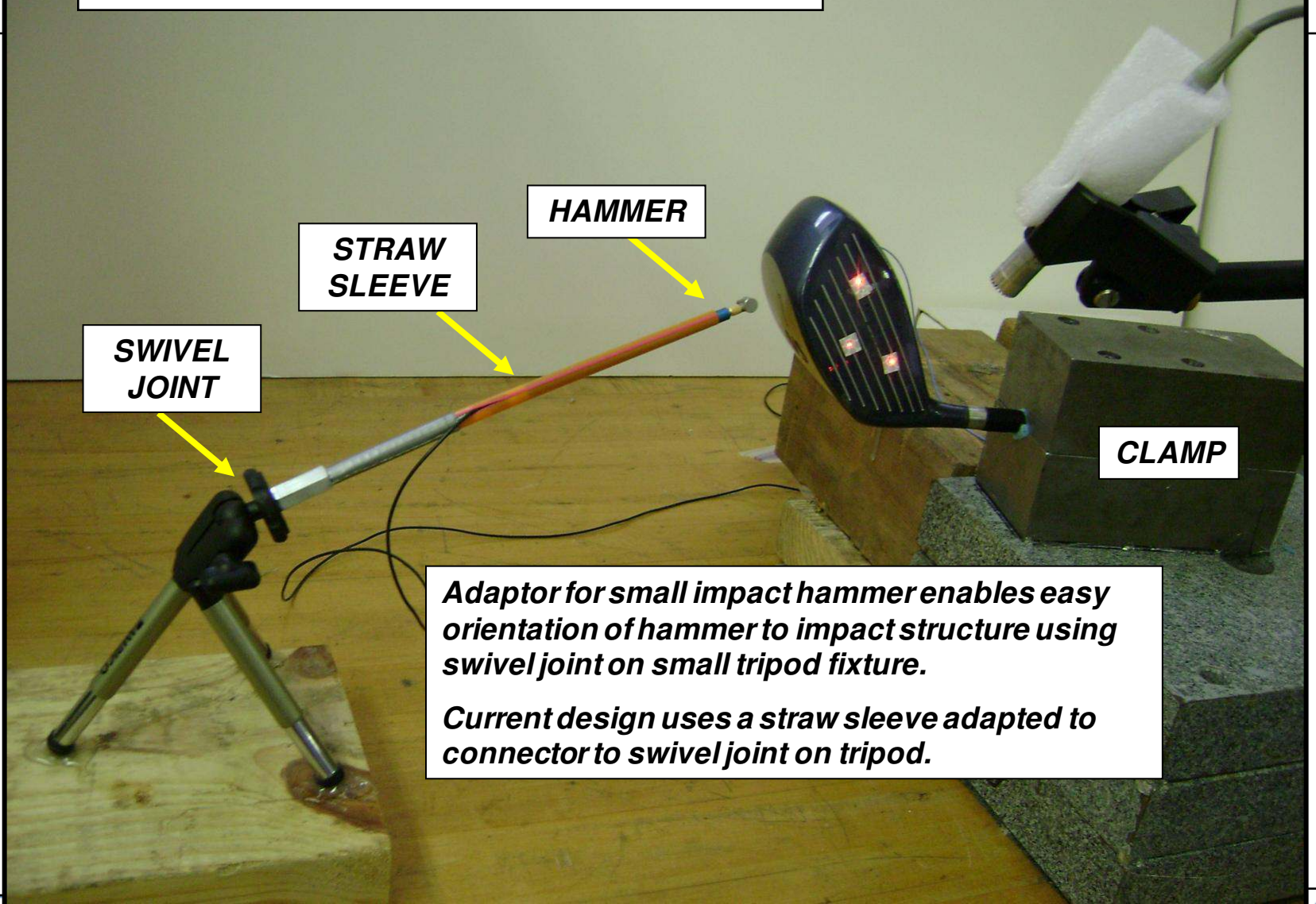

Impact Location

Control of input point and direction is very important

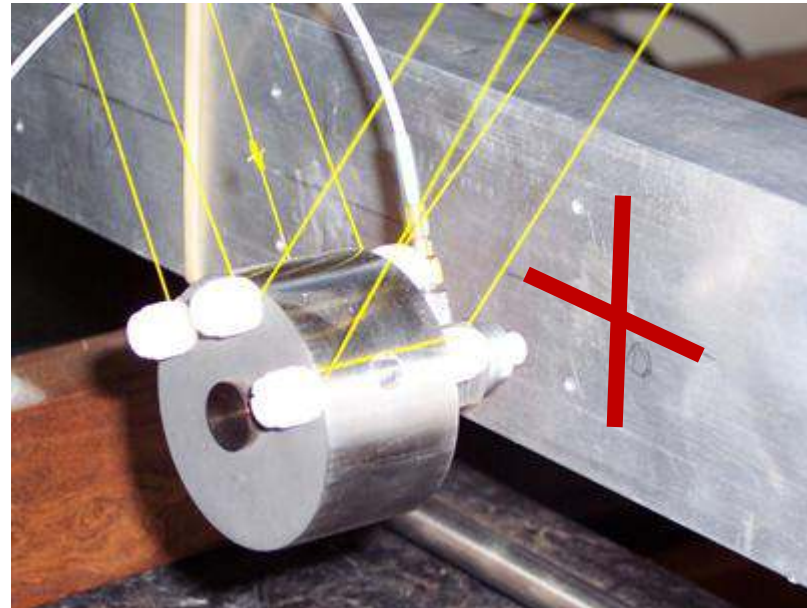
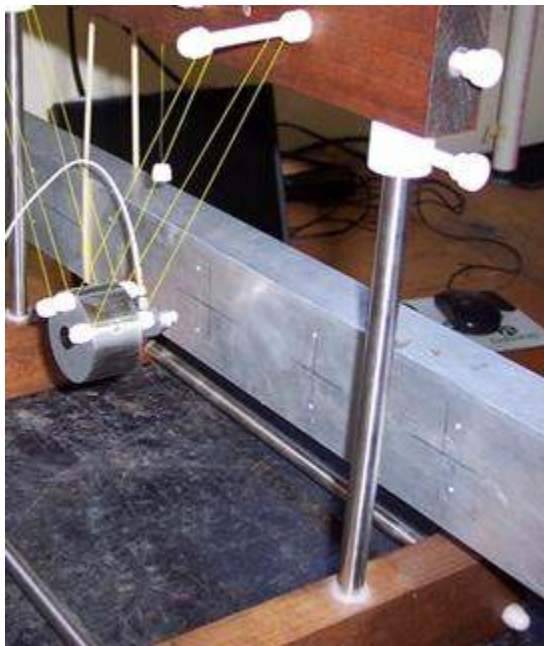

Accelerometer Saturation - But No Overload

Sometimes the response transducer may be too sensitive which generally may cause an overload.

But there are times when the accelerometer and the signal conditioner may not overload the data acquisition system BUT may be distorted due to saturation of the signal conditioner.

Accelerometer Saturation - But No Overload

Accelerometer too sensitive

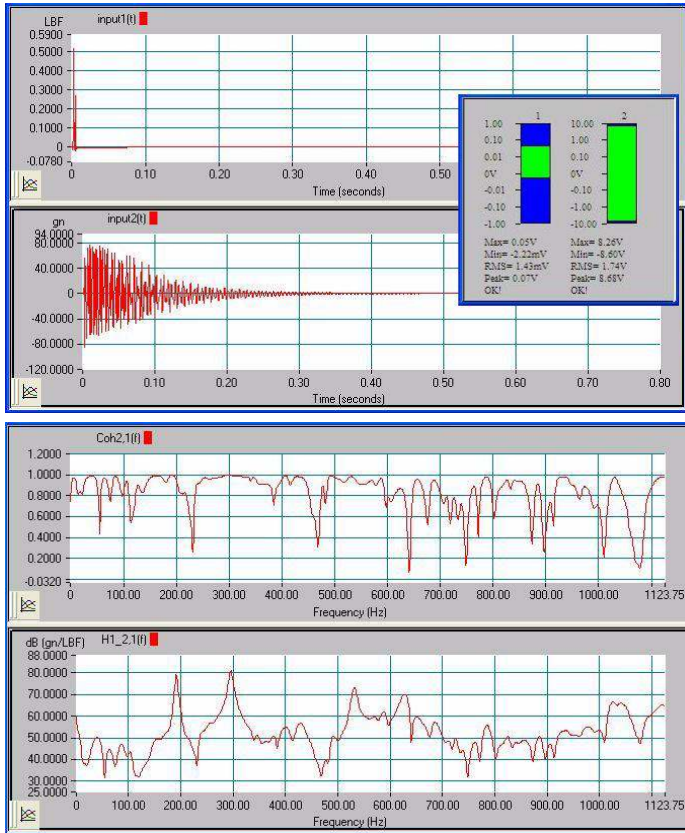

Accelerometer with proper sensitivity

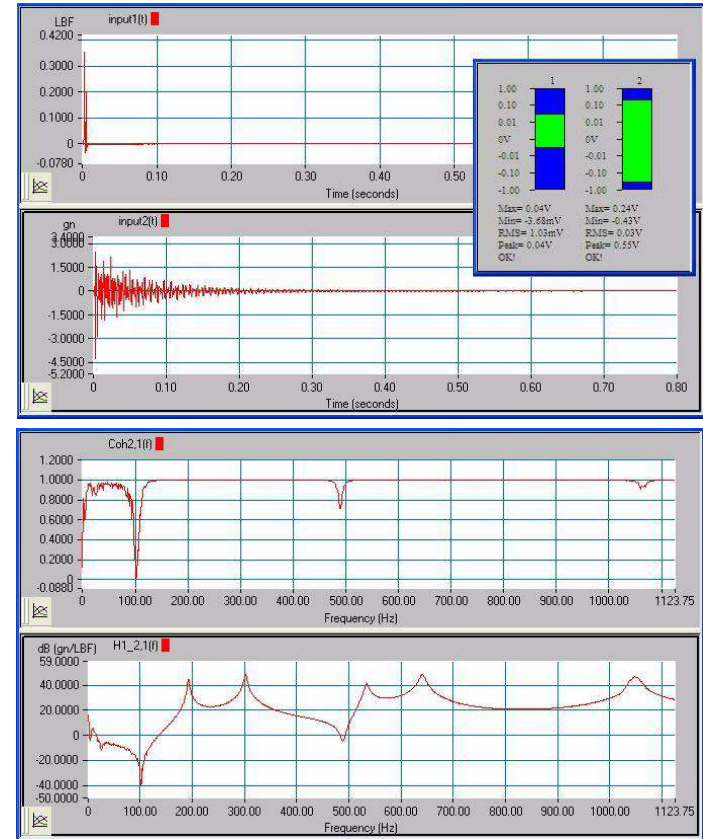

Analyzer ICP / External ICP / DC Accelerometer Comparison

DC 200mv/g

DC 1V/g

ICP 1V/g

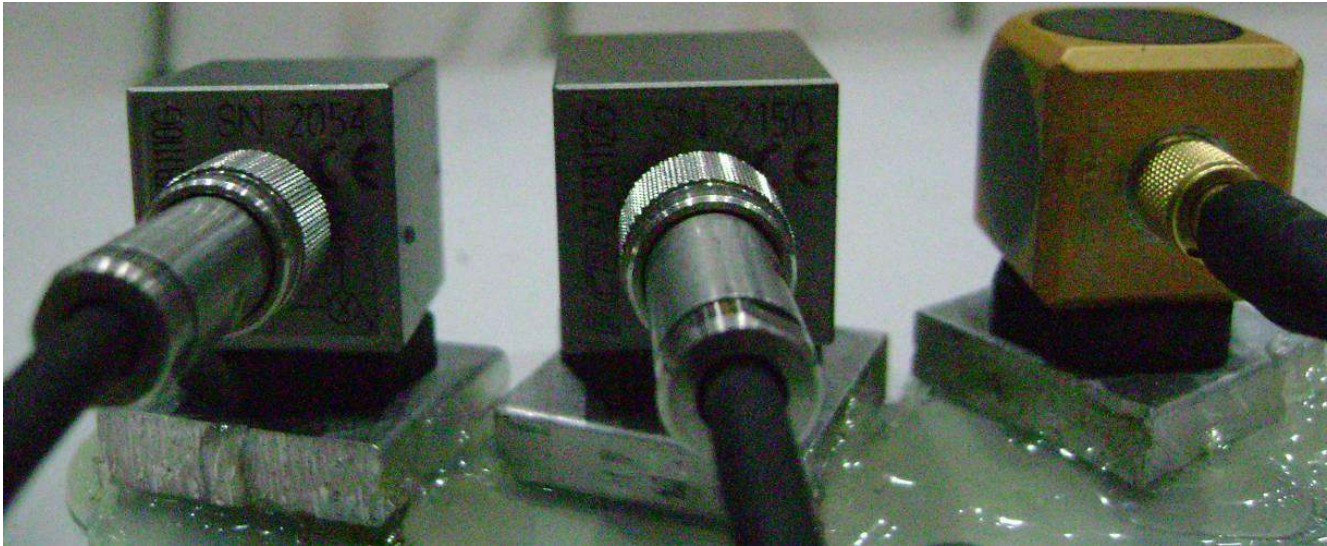

Analyzer ICP / External ICP / DC Accelerometer Comparison

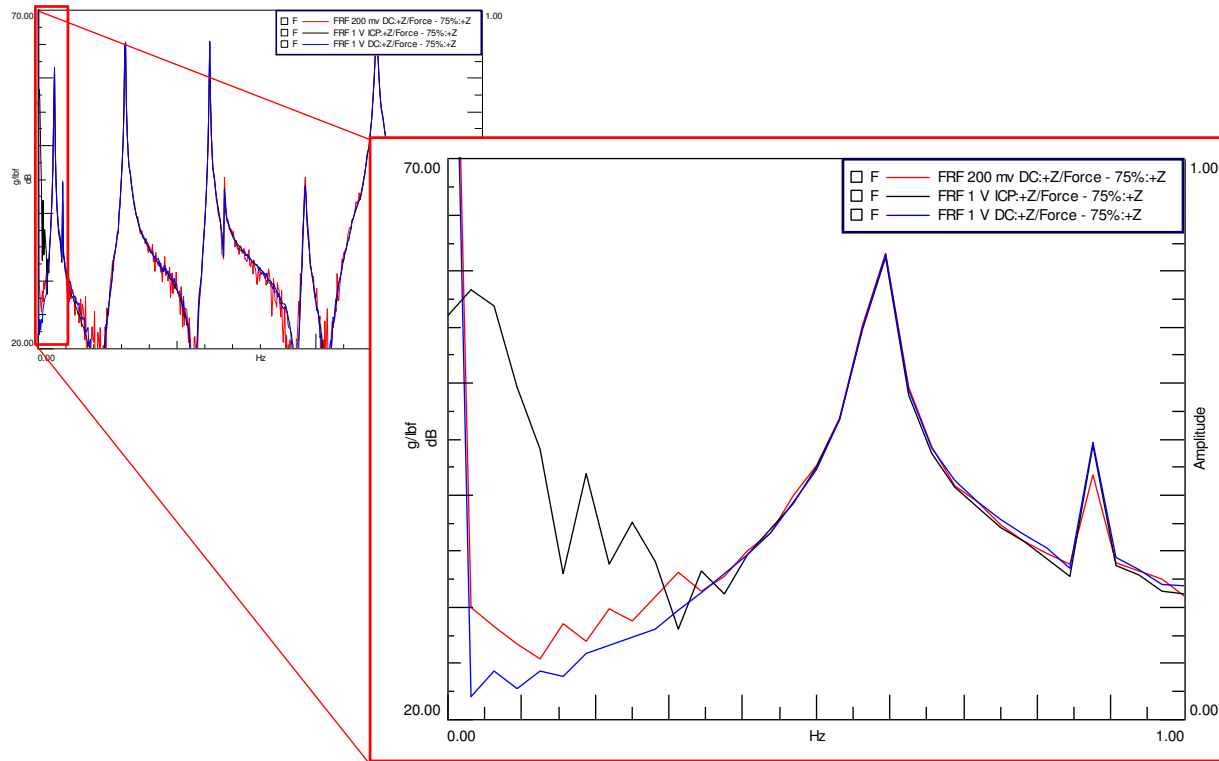

How Hard Should I Hit - Air Capsules

The hammer kits normally have the ability to use a variety of different tips to customize the input spectrum.

But what happens if some impacts are harder and some are softer? Does this affect the input excitation spectrum?

Depending on the hammer tip, this can be significant.

Air Capsule

Plastic Cap on Hard White Tip

Hard White Tip

SOFT HIT

MEDIUM HIT

HARD HIT

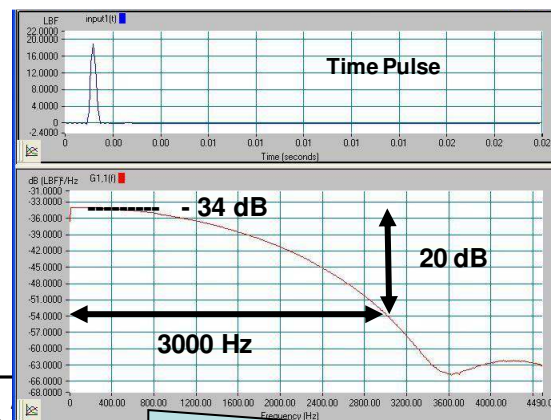
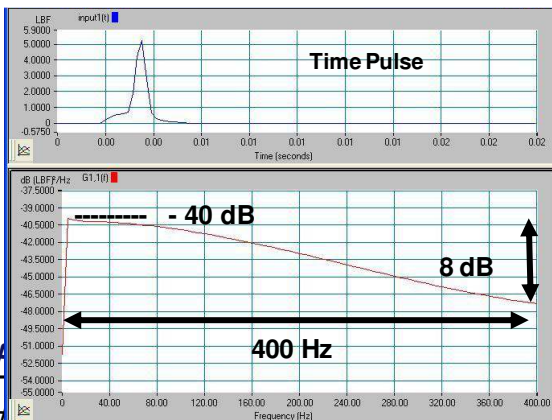
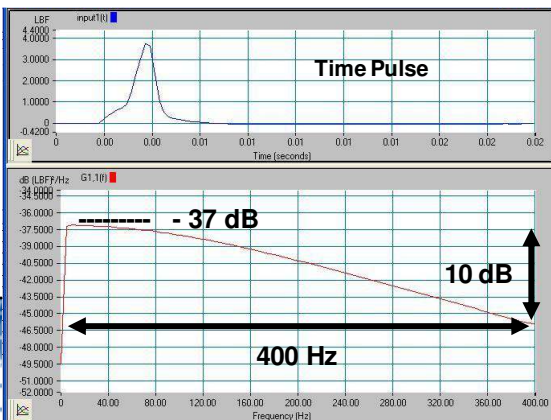
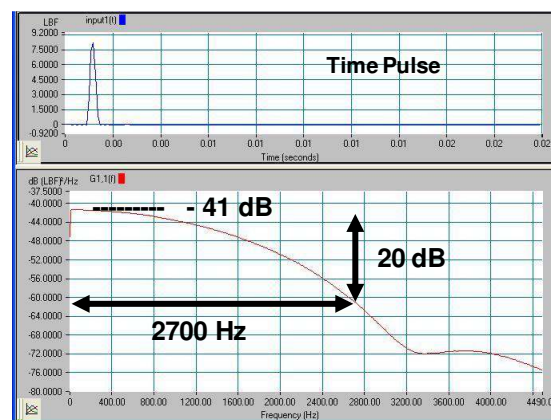
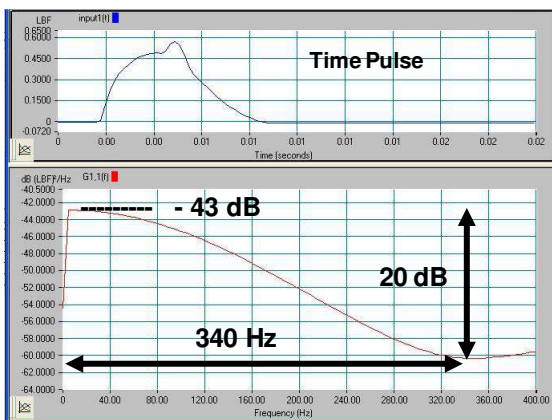
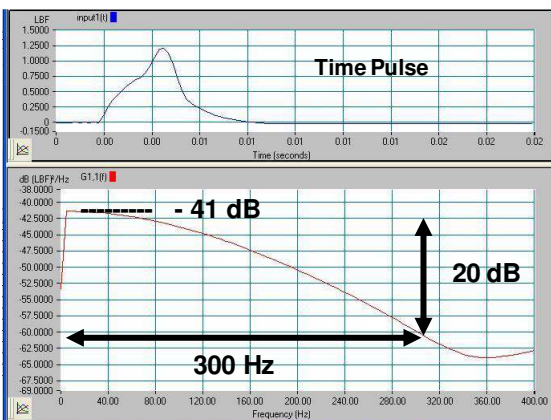
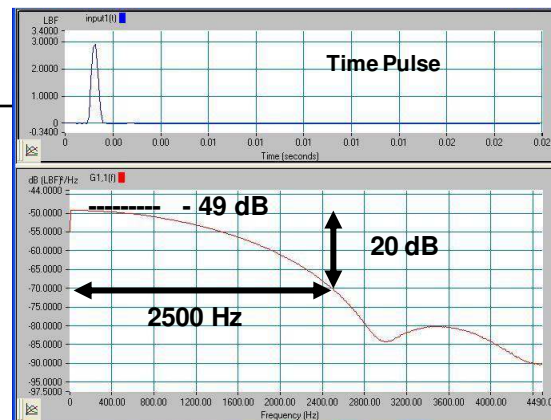
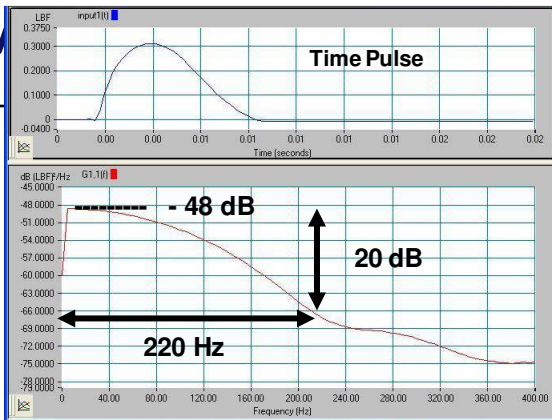
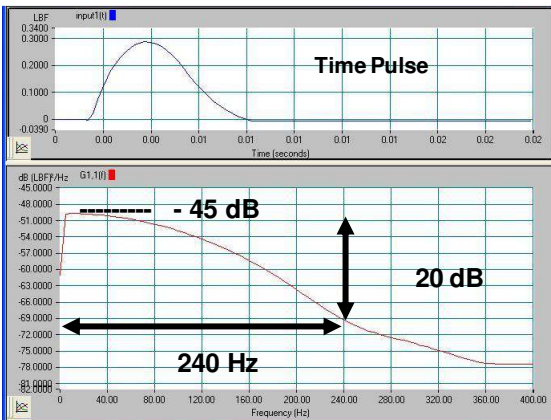

INCREASING IMPACT HAMMER FORCE LEVEL

INCREASING HAMMER TIP HARDNESS



Selection of Measurement Locations

So what are the chances that you would pick 9 of the worst possible measurement locations for a plate ???



August 1998 - Modal Space Articles

Excitation - Do's and Don'ts

67

*Dr. Peter Avitabile
Structural Dynamics & Acoustic Systems Lab*



Selection of Measurement Locations

FE Model
Test Model

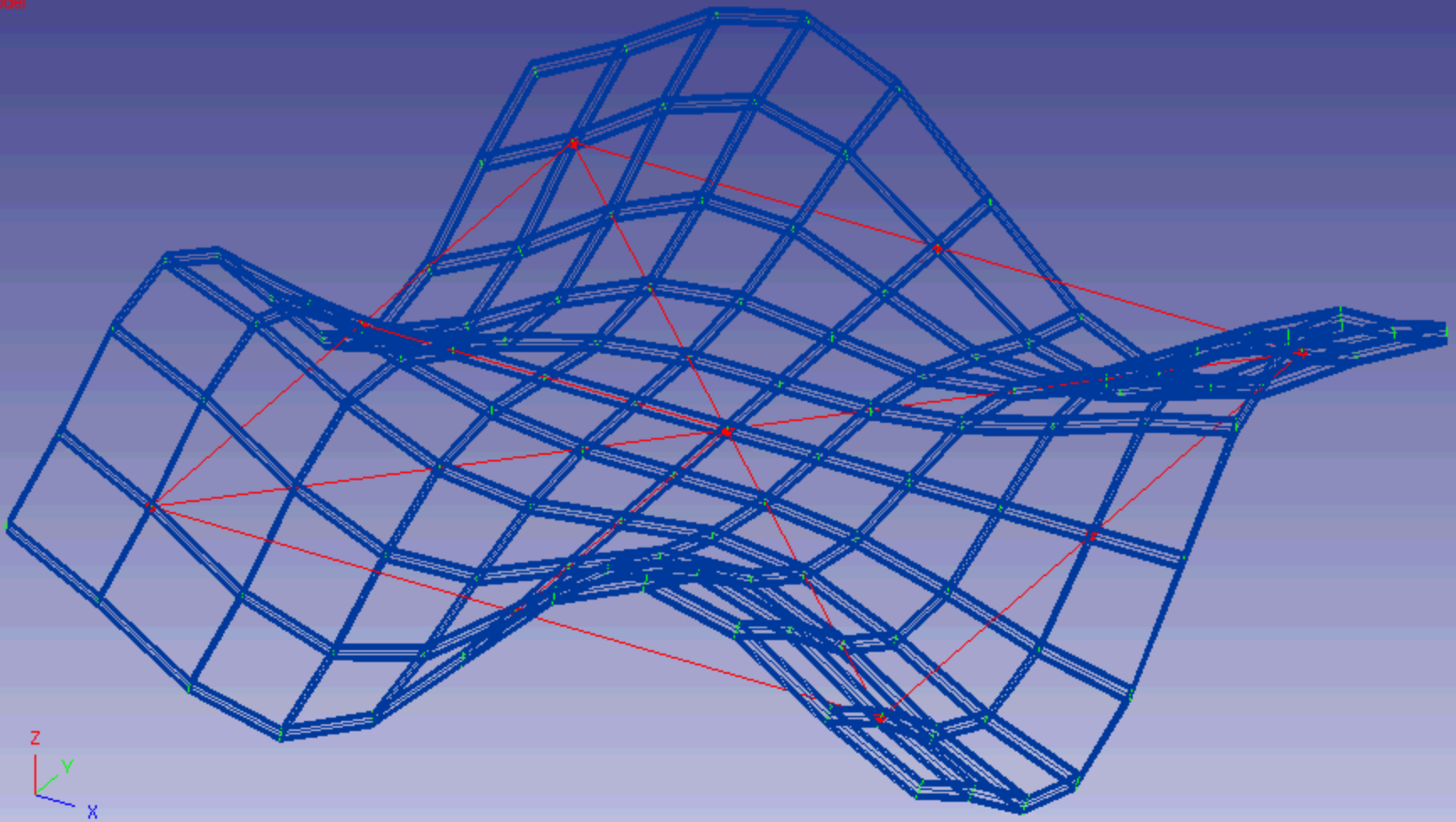

The Modal Question

Do these two test yield the same modal information?

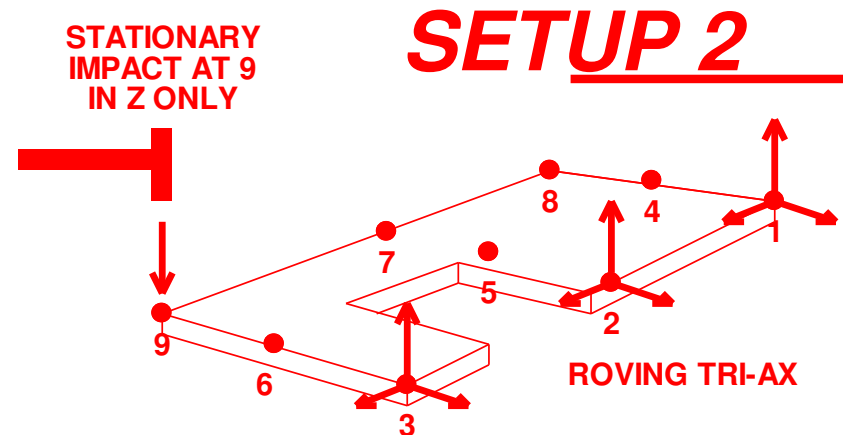
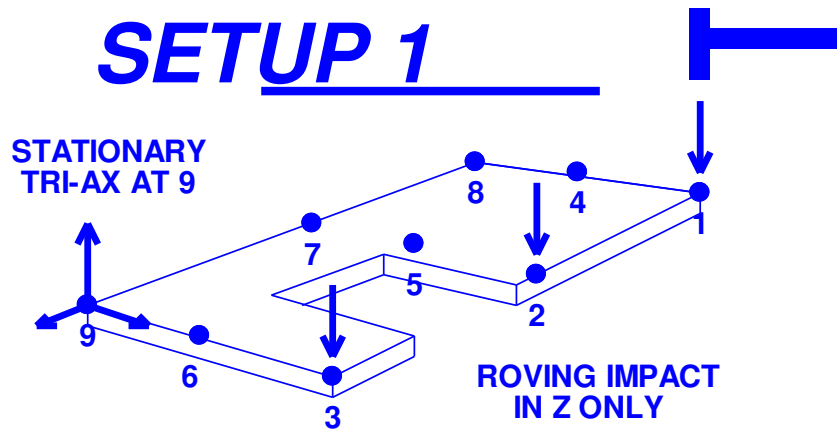

Reference Selection

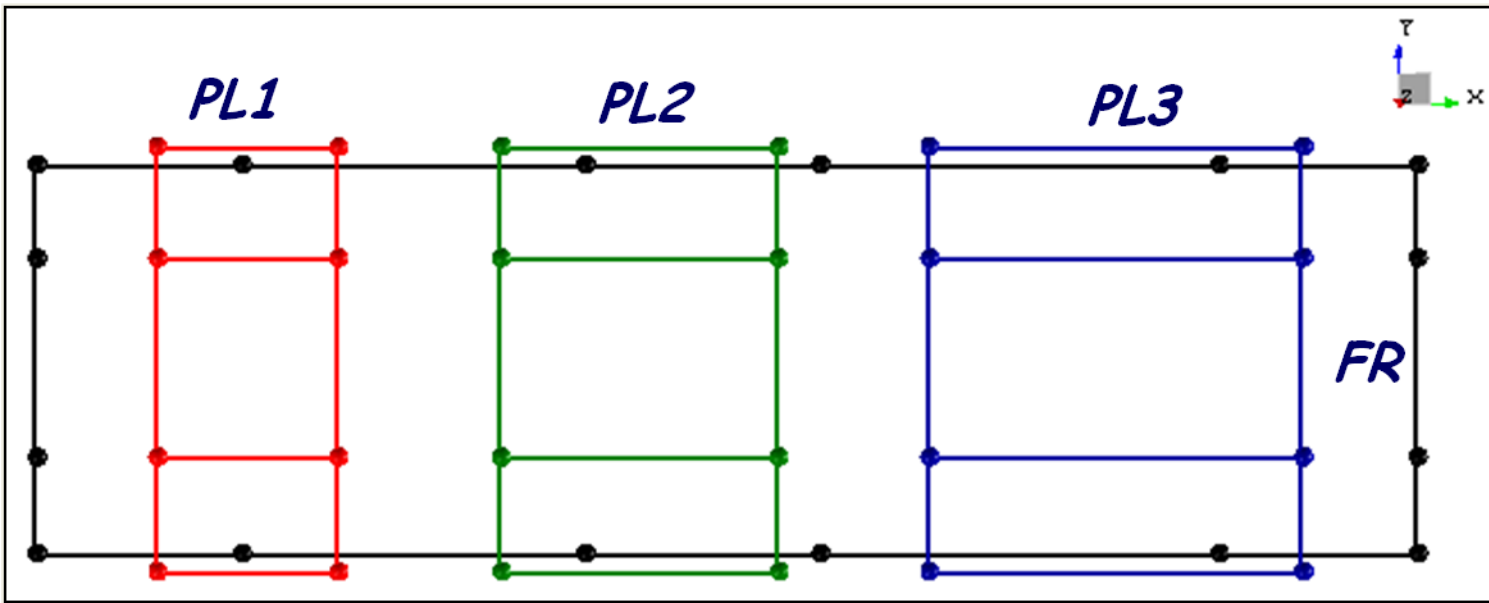
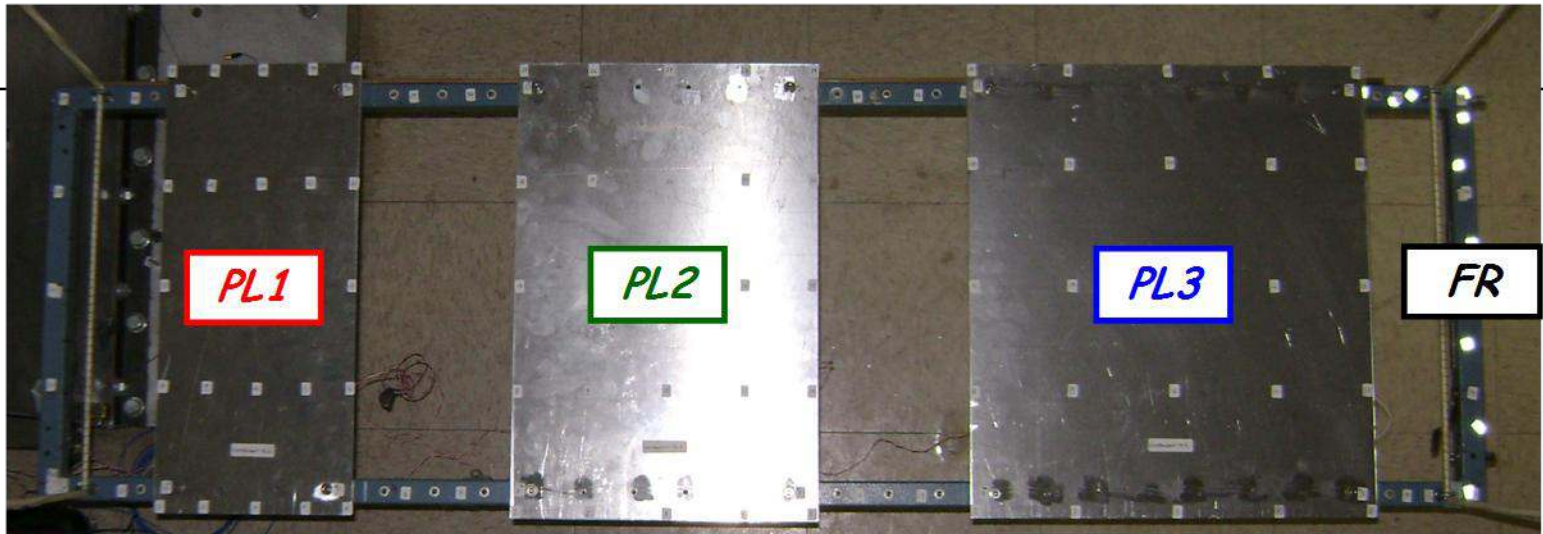

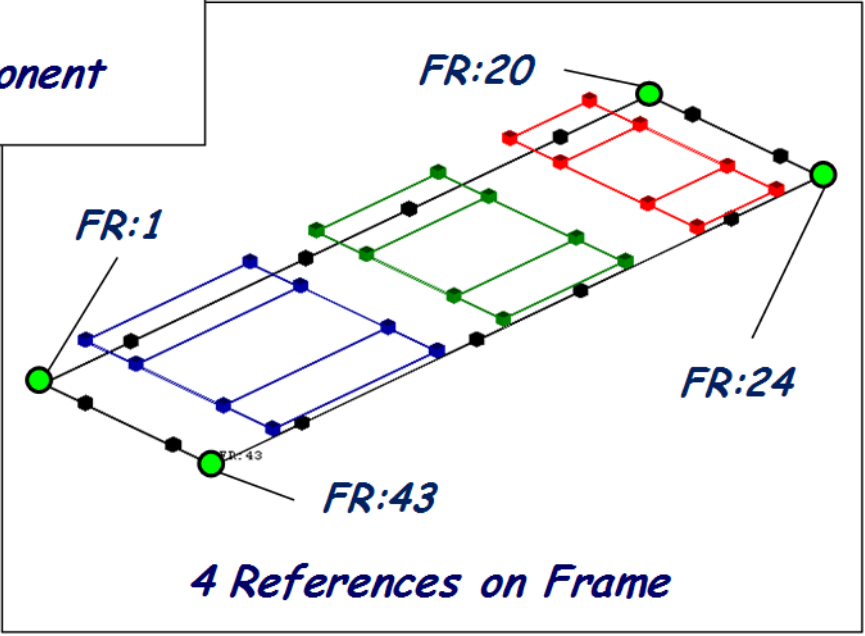
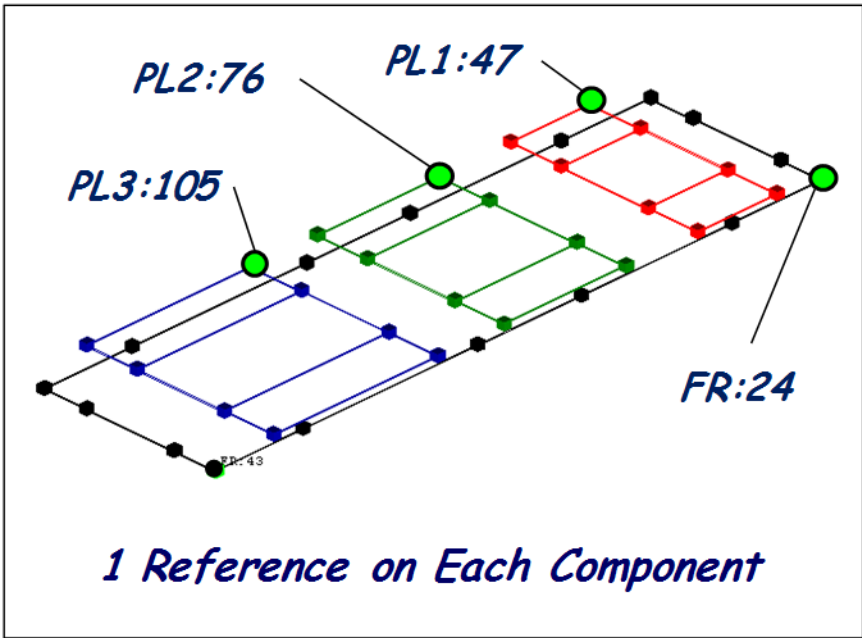

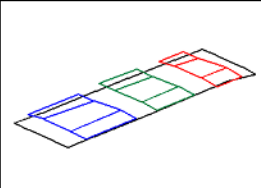
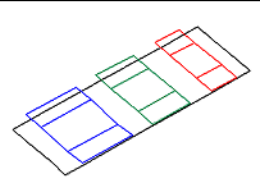
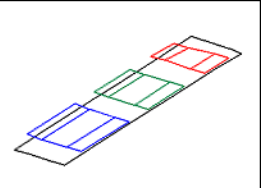
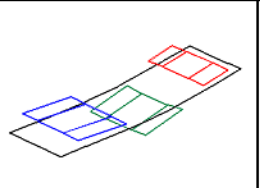
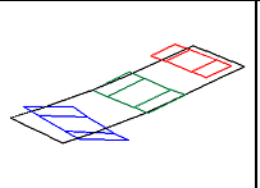
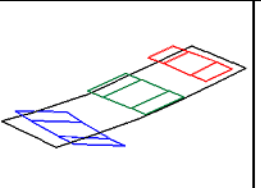
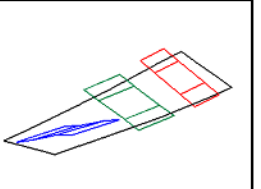
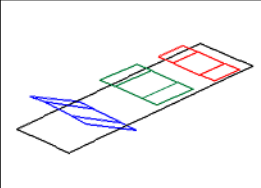
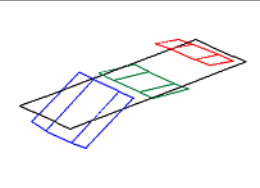
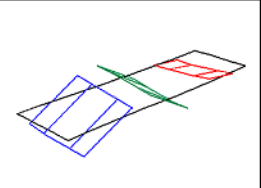
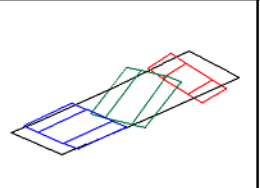
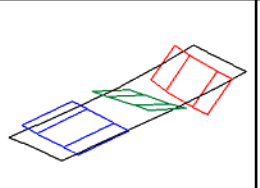
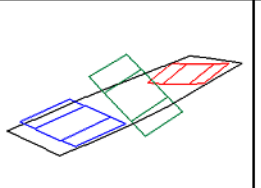
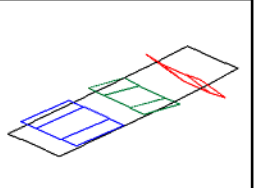
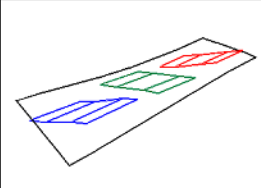
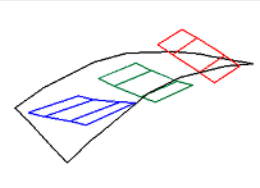
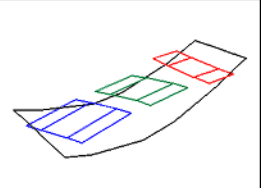
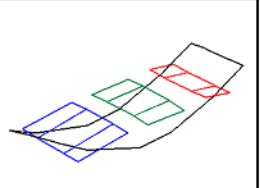
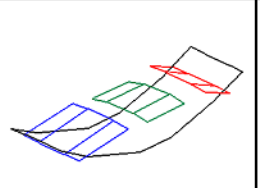
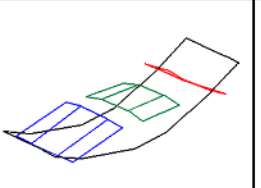
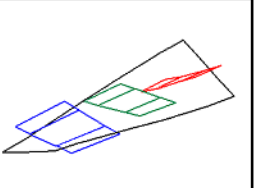
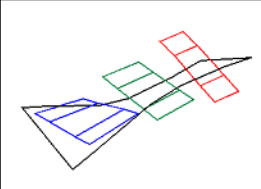
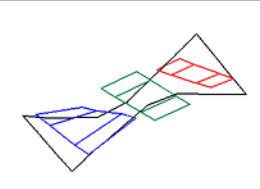
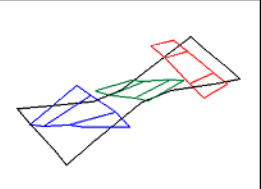
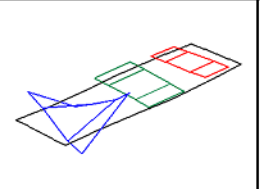
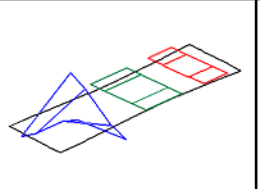
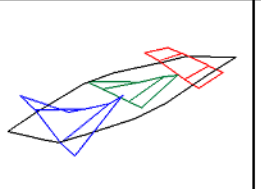
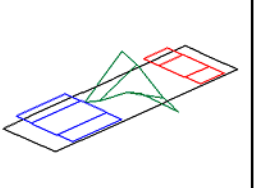
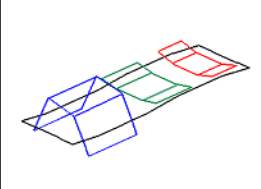
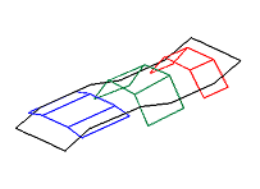
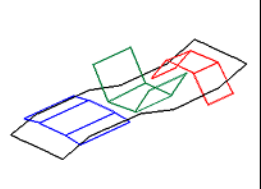
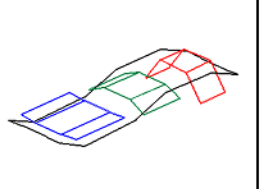
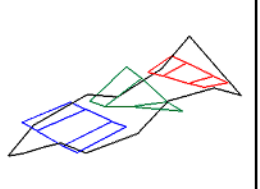
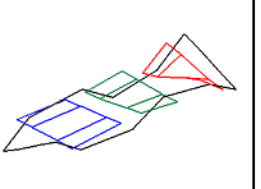
<i>Mode 1 - 1.86 Hz</i>	<i>Mode 2 - 2.85 Hz</i>	<i>Mode 3 - 3.02 Hz</i>	<i>Mode 4 - 25.37 Hz</i>	<i>Mode 5 - 29.01 Hz</i>	<i>Mode 6 - 30.16 Hz</i>	<i>Mode 7 - 33.62 Hz</i>
						
<i>Mode 8 - 35.60 Hz</i>	<i>Mode 9 - 37.58 Hz</i>	<i>Mode 10 - 38.70 Hz</i>	<i>Mode 11 - 39.62 Hz</i>	<i>Mode 12 - 43.04 Hz</i>	<i>Mode 13 - 44.23 Hz</i>	<i>Mode 14 - 46.48 Hz</i>
						
<i>Mode 15 - 54.44 Hz</i>	<i>Mode 16 - 58.80 Hz</i>	<i>Mode 17 - 61.68 Hz</i>	<i>Mode 18 - 62.46 Hz</i>	<i>Mode 19 - 65.08 Hz</i>	<i>Mode 20 - 69.79 Hz</i>	<i>Mode 21 - 72.71 Hz</i>
						
<i>Mode 22 - 77.90 Hz</i>	<i>Mode 23 - 96.39 Hz</i>	<i>Mode 24 - 99.50 Hz</i>	<i>Mode 25 - 115.58 Hz</i>	<i>Mode 26 - 120.57 Hz</i>	<i>Mode 27 - 133.93 Hz</i>	<i>Mode 28 - 153.47 Hz</i>
						
<i>Mode 29 - 159.47 Hz</i>	<i>Mode 30 - 163.29 Hz</i>	<i>Mode 31 - 164.99 Hz</i>	<i>Mode 32 - 170.14 Hz</i>	<i>Mode 33 - 180.35 Hz</i>	<i>Mode 34 - 186.85 Hz</i>	
						

Reference Selection - Where Should Reference Be Located?

Random Point Selection

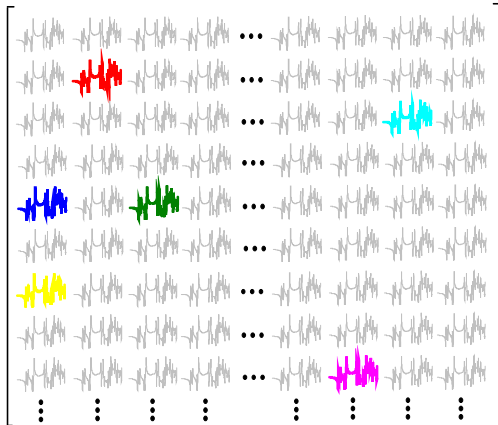

Organized Point Selection

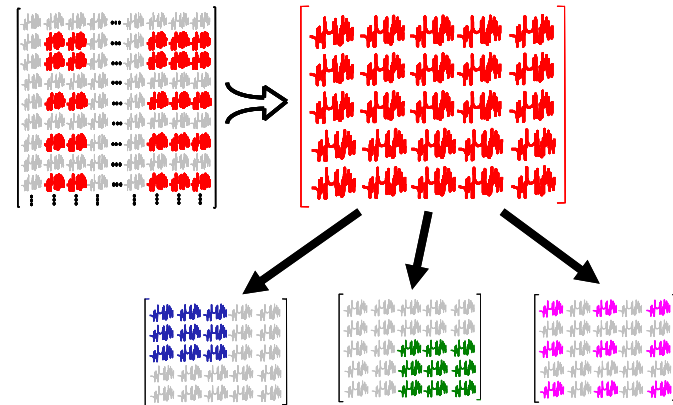

Composite Plate Pseudo-Repeated Root Example

A plate structure with suspected pseudo-repeated roots was tested to determine the appropriate reference locations

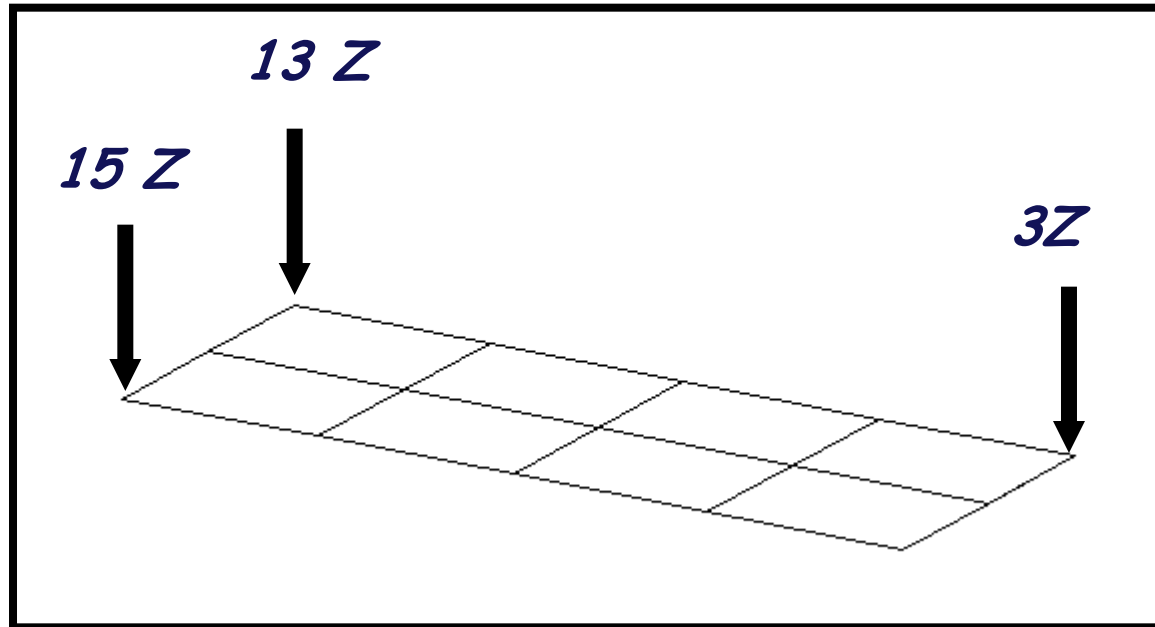

Composite Plate Pseudo-Repeated Root Example

A summation plot and typical drive point FRFS are shown

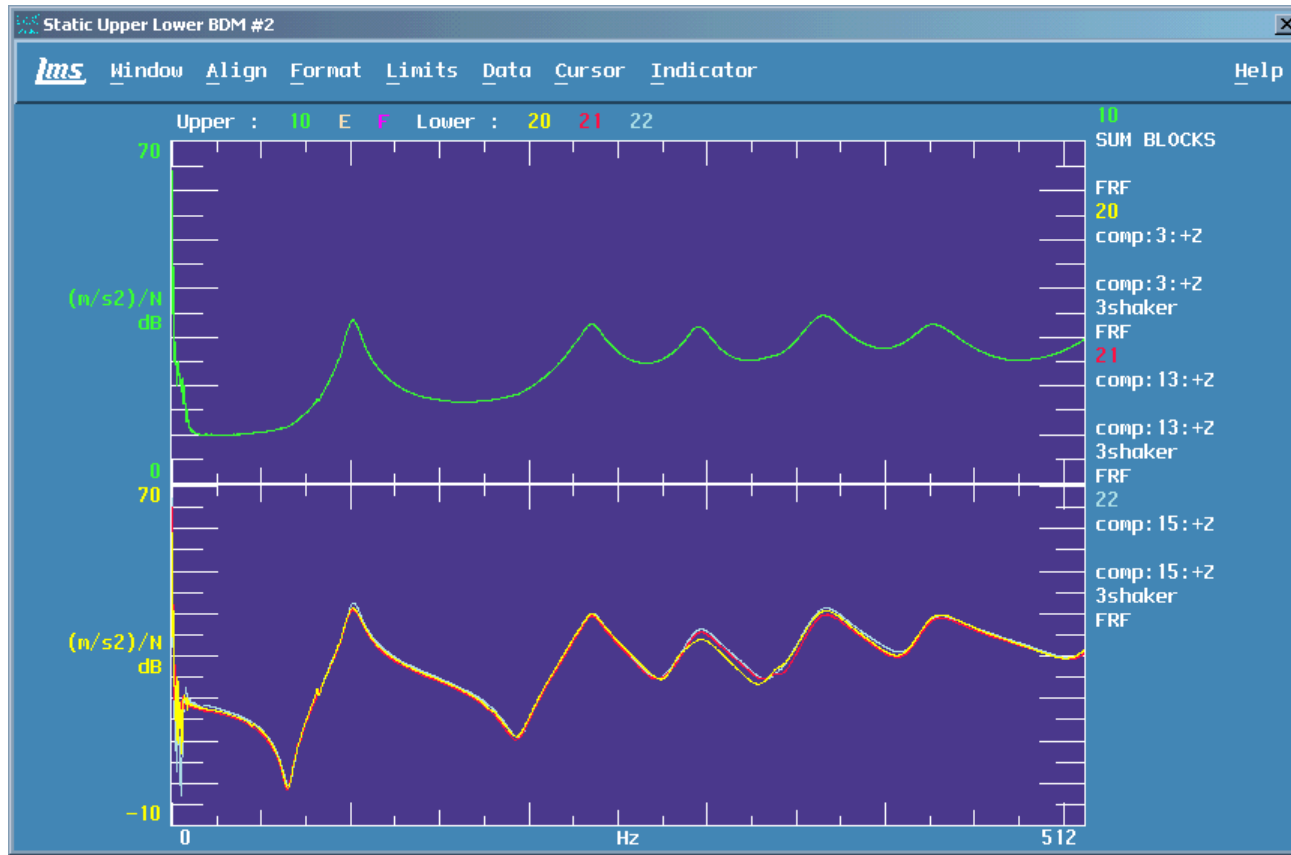

Composite Plate Pseudo-Repeated Root Example

Using all 3 references, TRIP identifies a repeated root

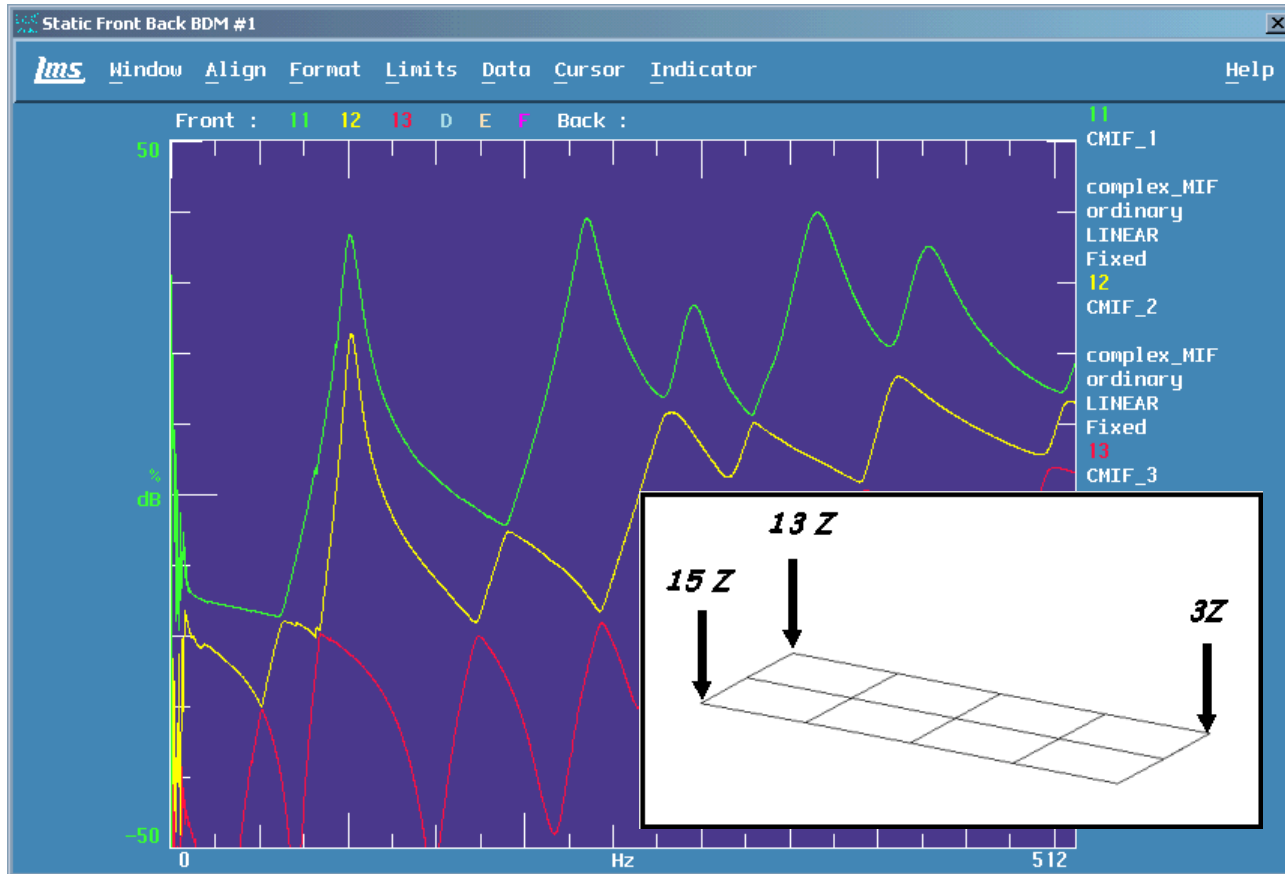

Note: plot only to 500 Hz

Composite Plate Pseudo-Repeated Root Example

Using references 3 Z & 15 Z, TRIP identifies repeated root

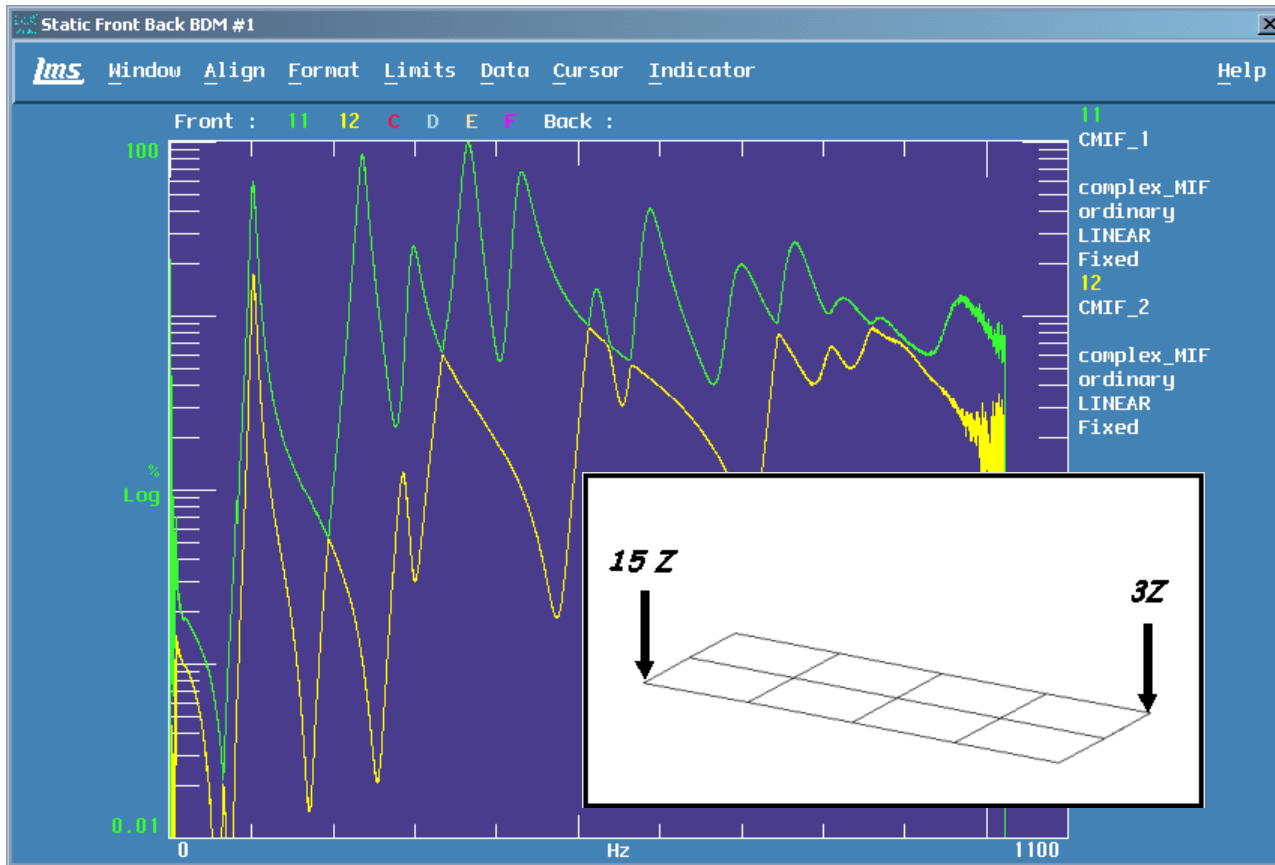

Composite Plate Pseudo-Repeated Root Example

Using references 13 Z & 15 Z, TRIP identifies repeated root

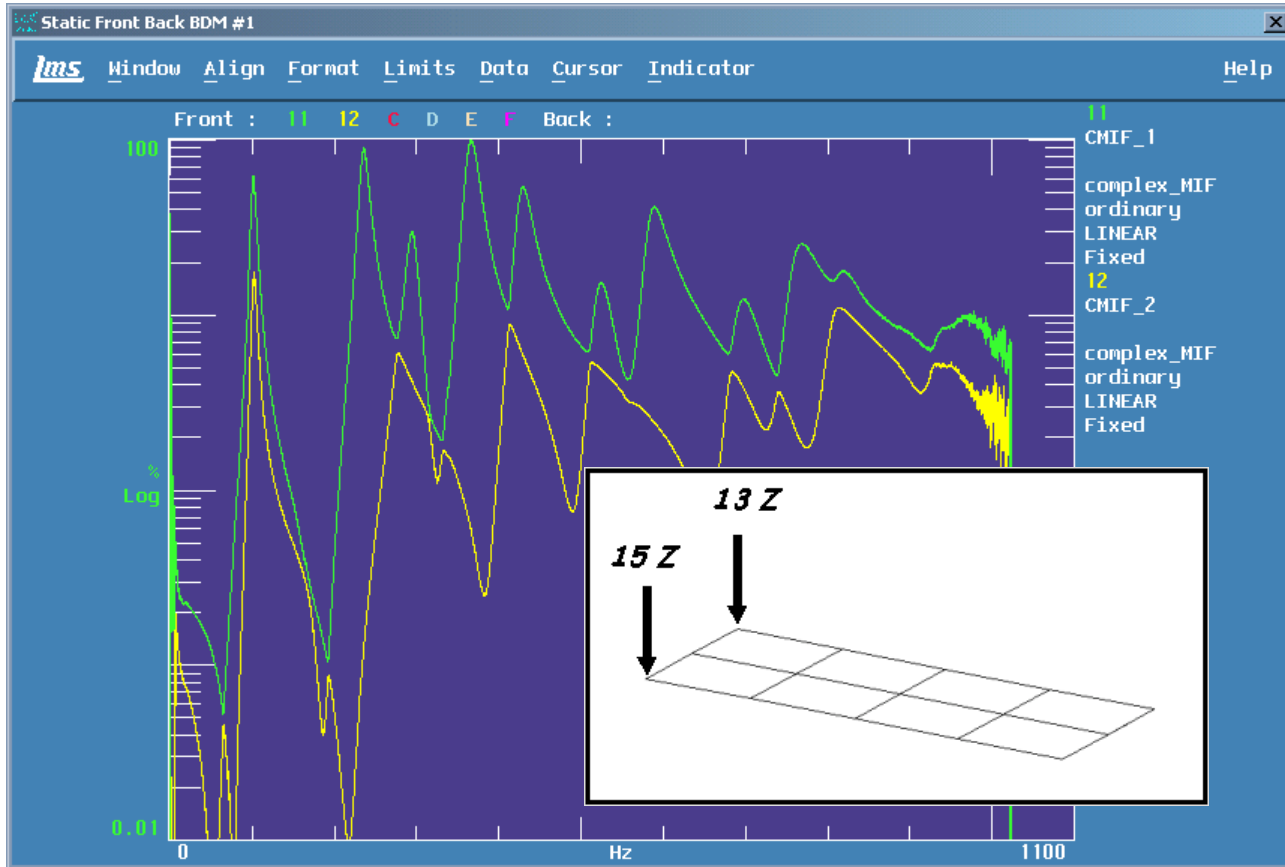

Composite Plate Pseudo-Repeated Root Example

Using references 3 Z & 13 Z, does not !!!!!!!

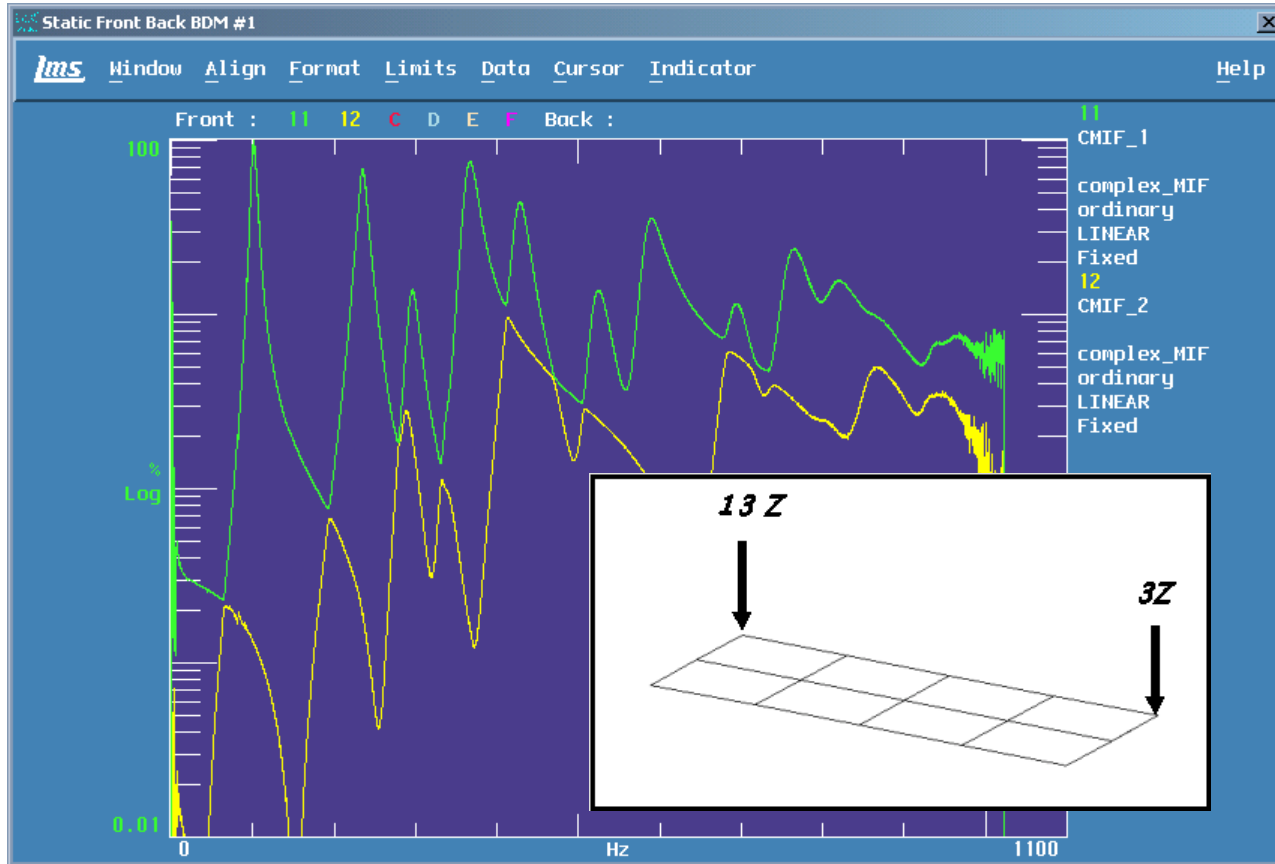

Shaker Excitation

Shaker Excitation

Objectives of this lecture:

- *Overview shaker testing considerations*
- *Identify some typical set up concerns*
- *Provide some examples*

Much was previously
done at IMAC 27/29

IMAC 27 presentation covered excitation techniques

IMAC 29 presentation covered shaker testing considerations



Excitation Configuration

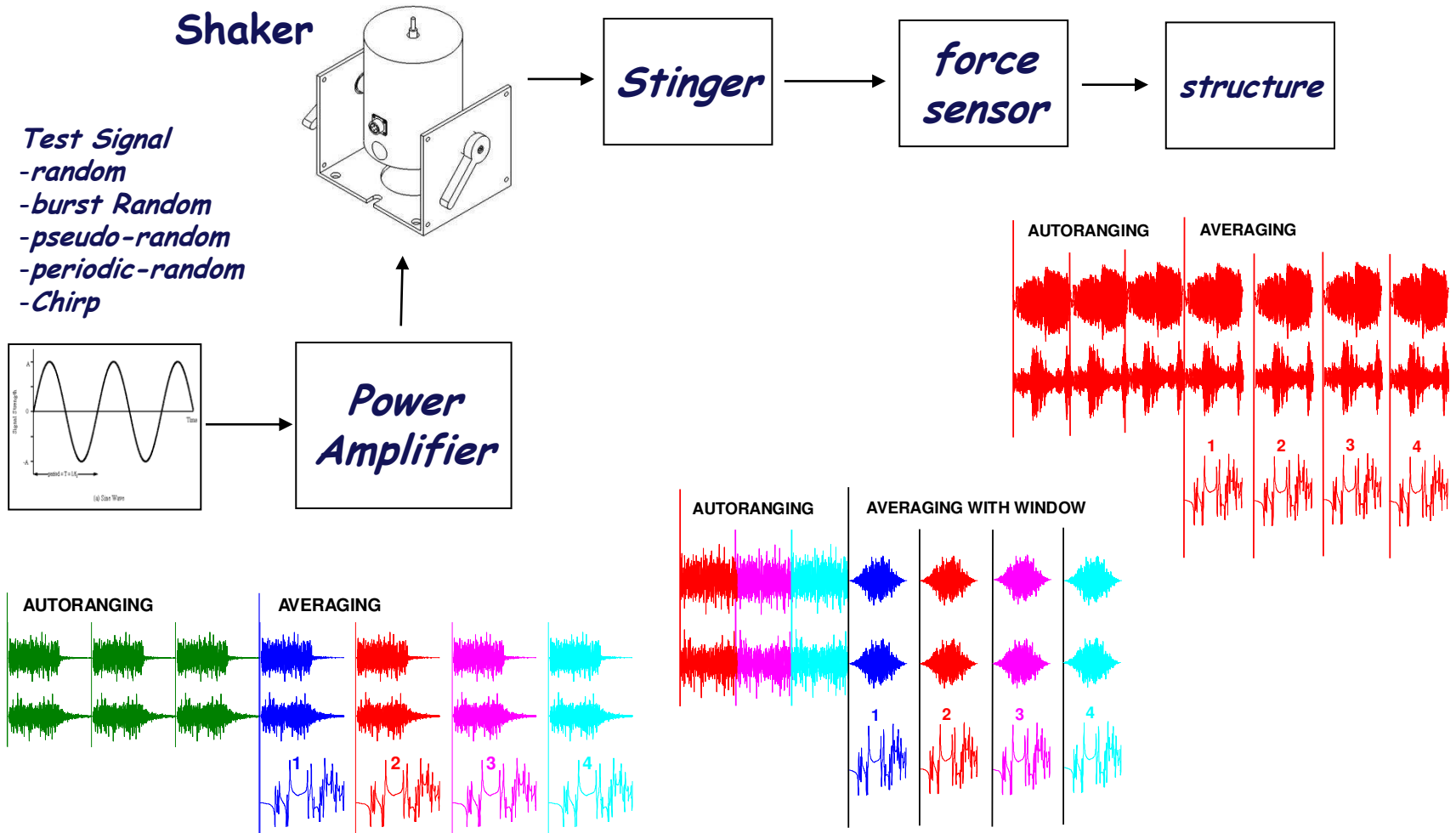

Reason for Stinger

Purpose of Stinger

- *Decouple shaker from test structure*
- *Force transducer between stinger and structure decouple forces acting in the axial direction only*
- *Forces acting in any other direction will be unaccounted for creating error in the measurements*

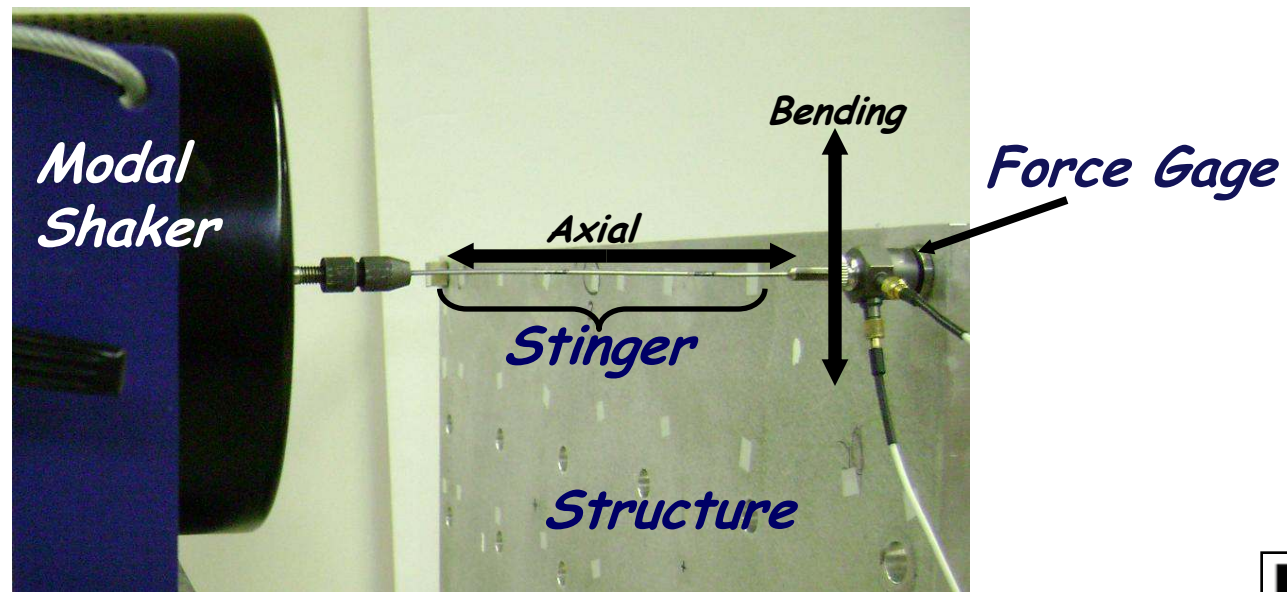

Possible Problems with Stinger

- *Location of stinger on structure may be affected by the local stiffness and/or structure deformation*

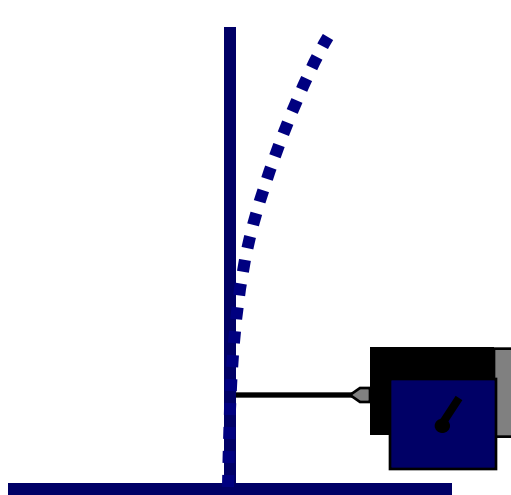

Axial stiffness

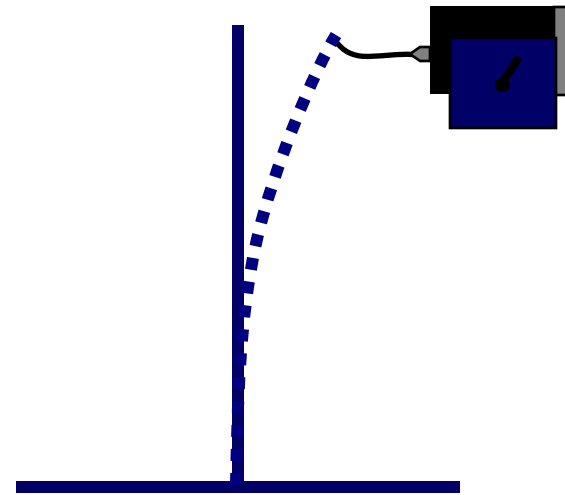

Axial and bending stiffness

Stinger Configuration with Through Hole Shaker

Modal Exciter

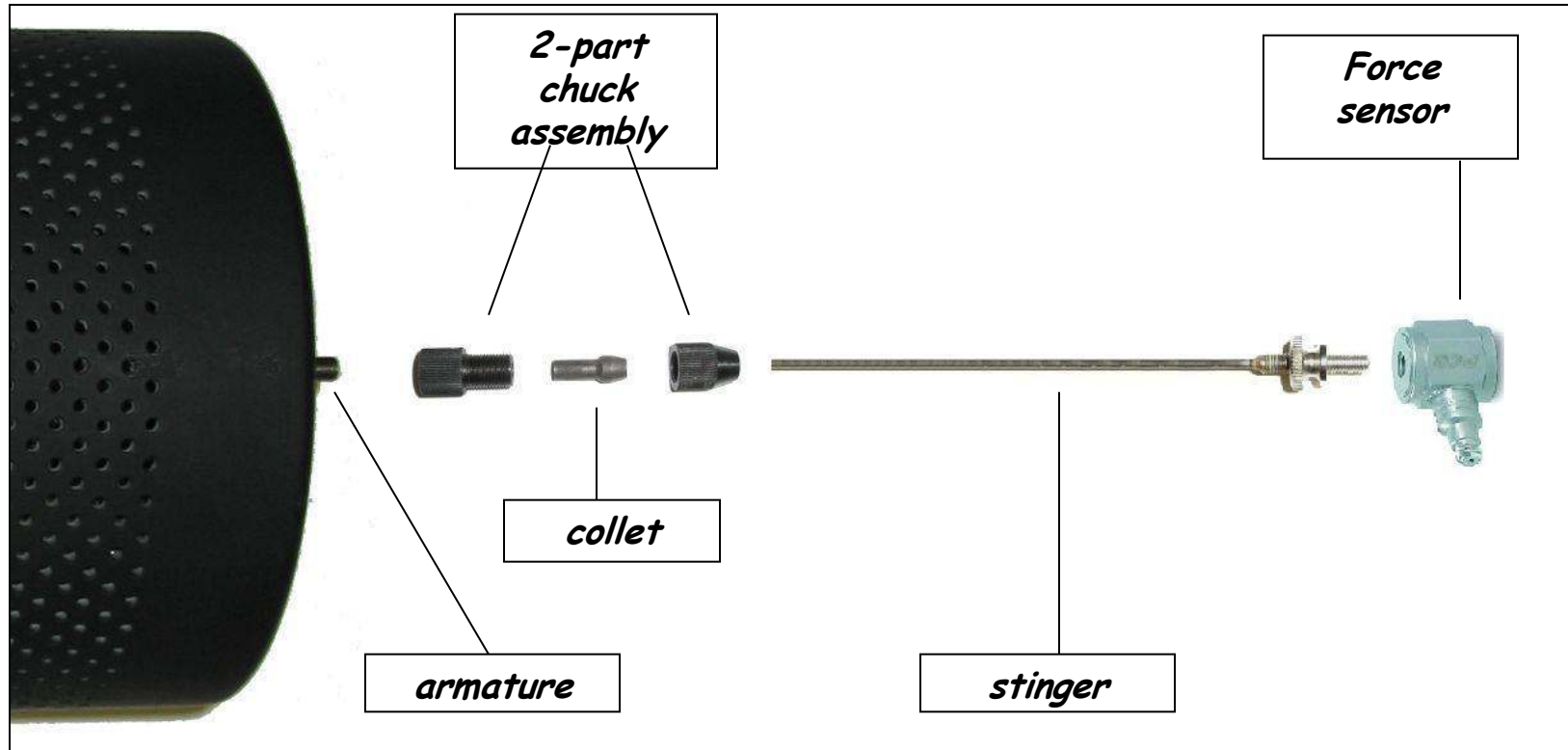

Test Structure

Multiple Input Shaker Excitation

Objectives of this part of lecture:

- *Identify some basics of MIMO testing*
- *Discuss several practical aspects of multiple input multiple output shaker testing*



Multiple Input Shaker Excitation

- *Provide a more even distribution of energy*
- *Simultaneously excite all modes of interest*
- *Multiple columns of FRF matrix acquired*
- *More consistent data is collected*
- *Same test time as SISO case*



Excitation Considerations - MIMO



Energy is distributed better throughout the structure making better measurements possible

Multiple referenced FRFs are obtained from MIMO test

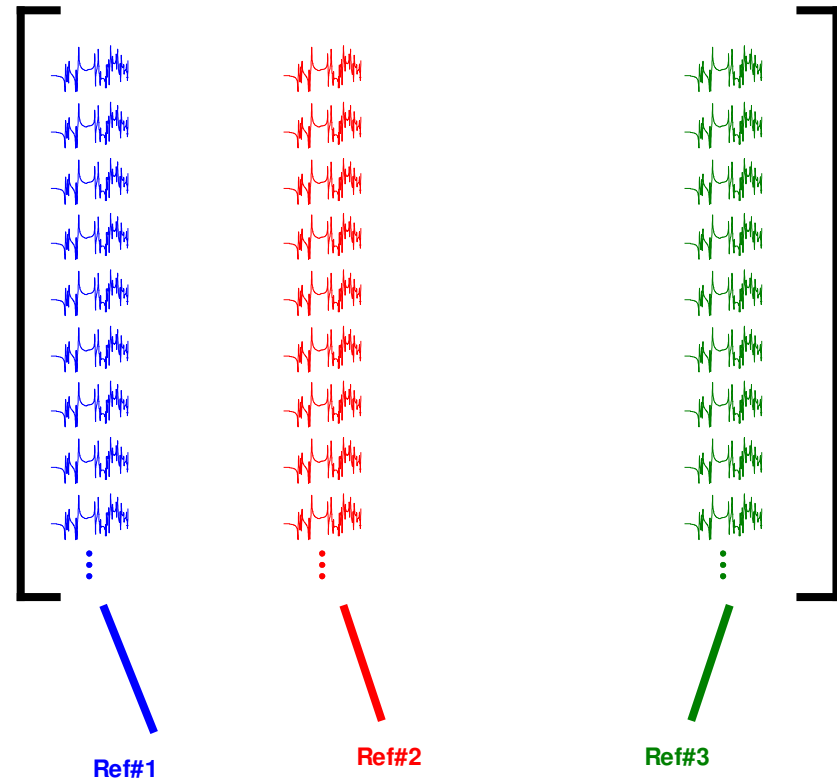

Excitation Considerations - MIMO

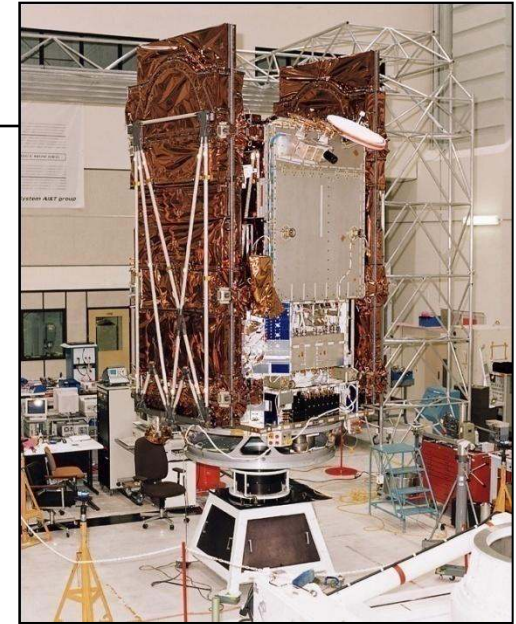
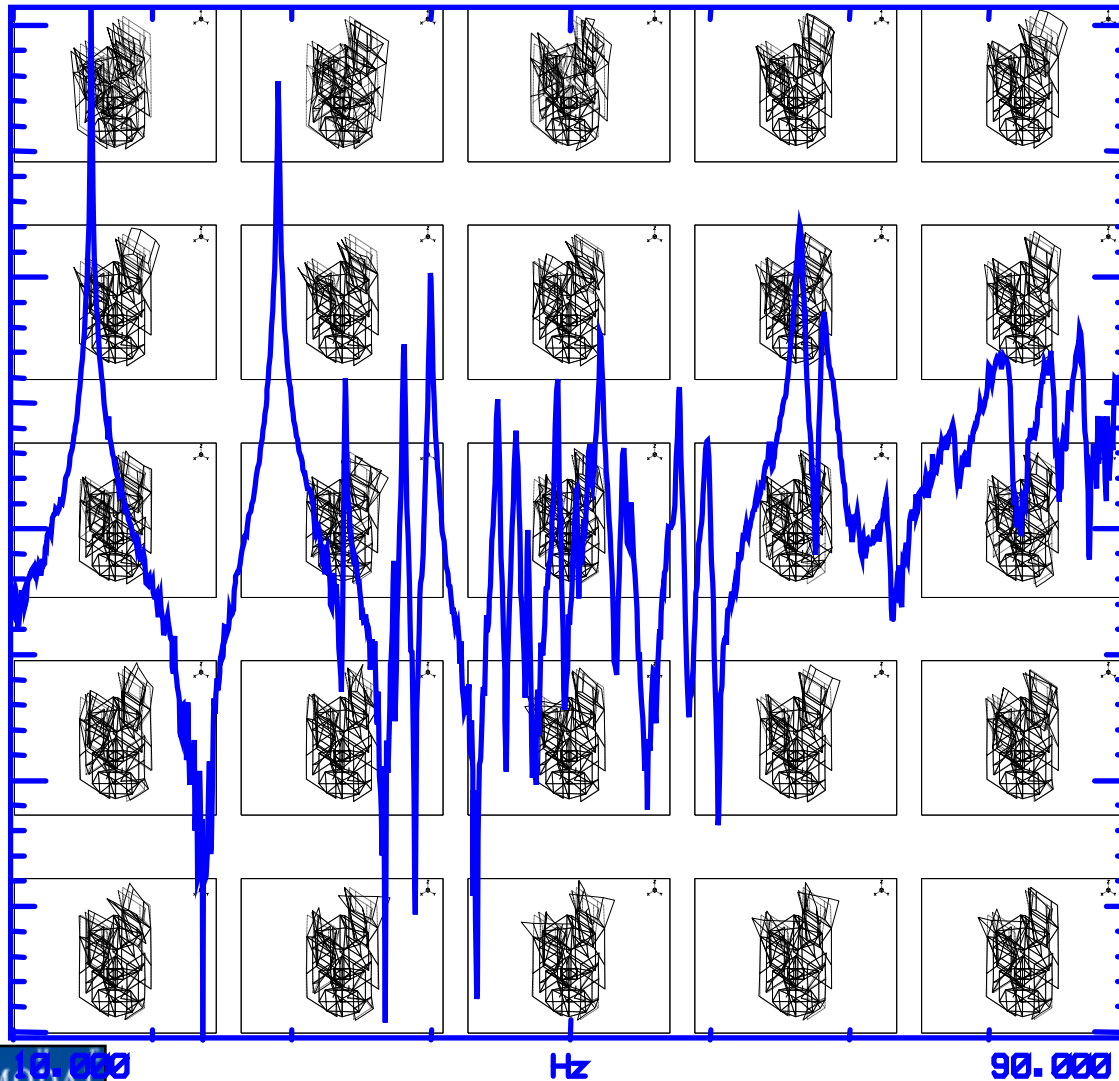

Large or complicated structures require special attention

Excitation Considerations - MIMO

Multiple shakers are needed in order to adequately shake the structure with sufficient energy to be able to make good measurements for FRF estimation

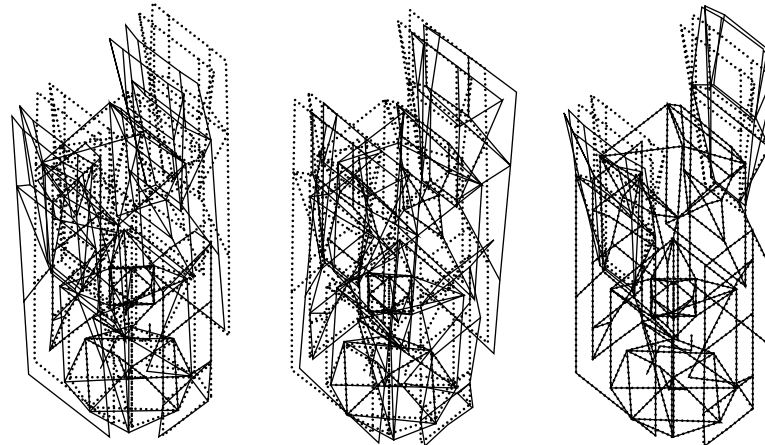
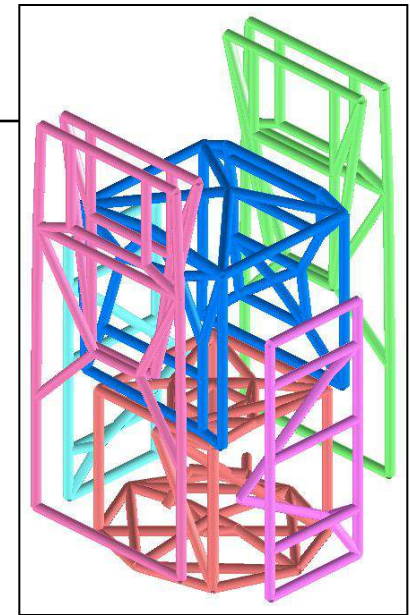
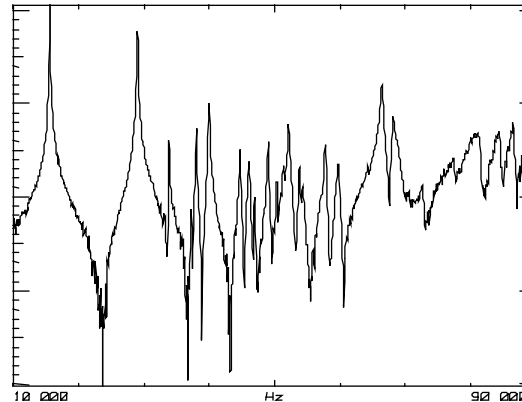

Frequently Asked Questions

Objectives of this part of lecture:

- Provide some measurements to illustrate issues*
- Revisit reciprocity*
- Compare impedance head vs force/accelerometer*
- Compare MIMO measurements*

SISO vs MIMO

Excitation technique is one necessary step to acquire better measurements (random/hann vs burst random).

But using MIMO instead of SISO is another important consideration.

And mass loading effects are also important

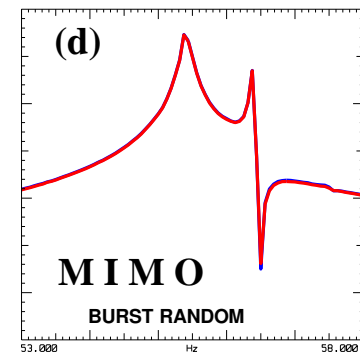
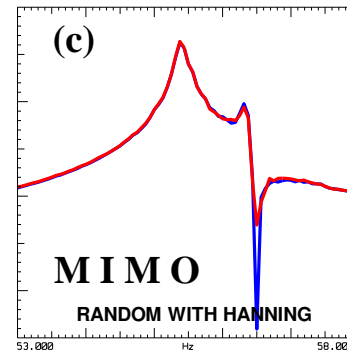
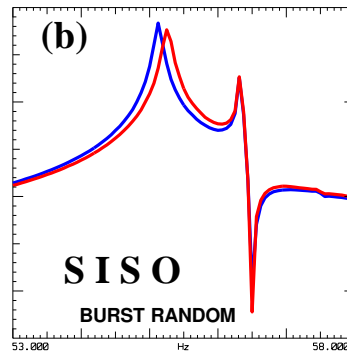
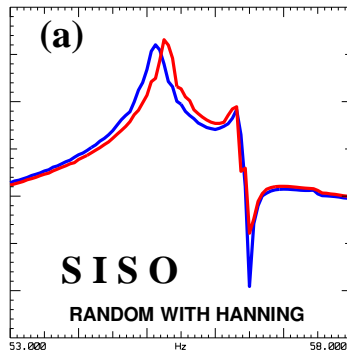

Shaker Mass Loading Effects

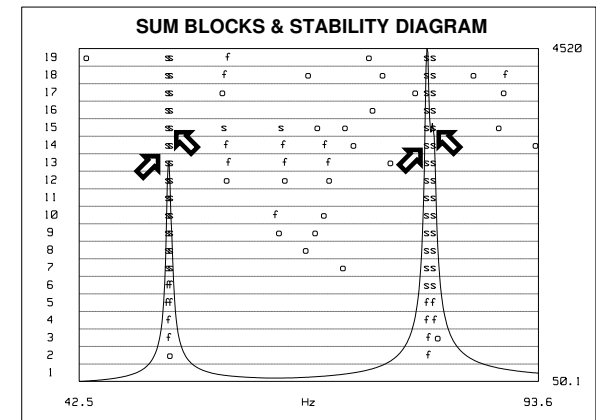
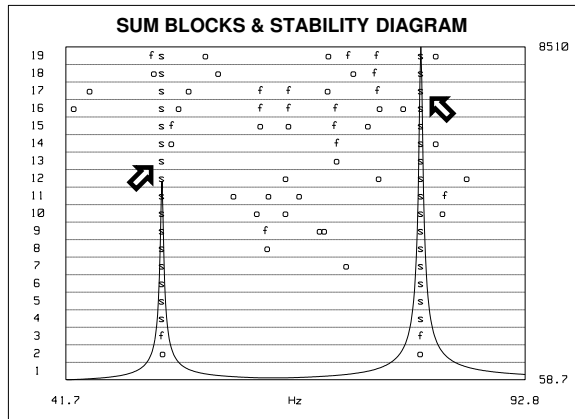
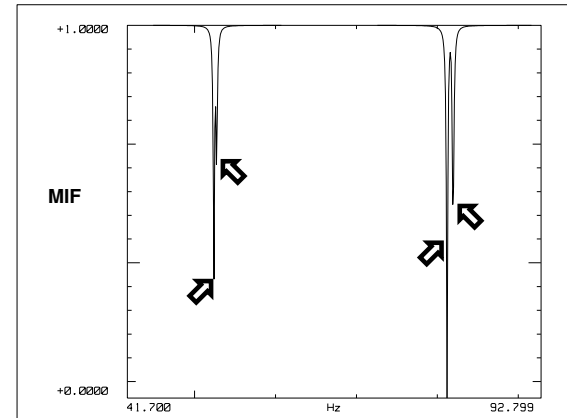
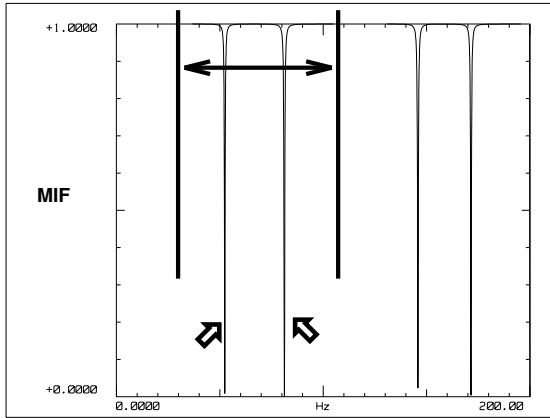
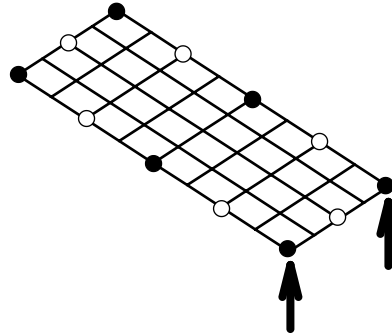

Shaker Mass Loading Effects

Three Measurement Setups - Compare Repeated Root:

No Mass Compensation

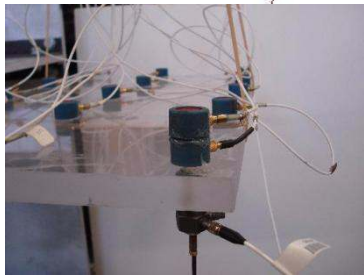
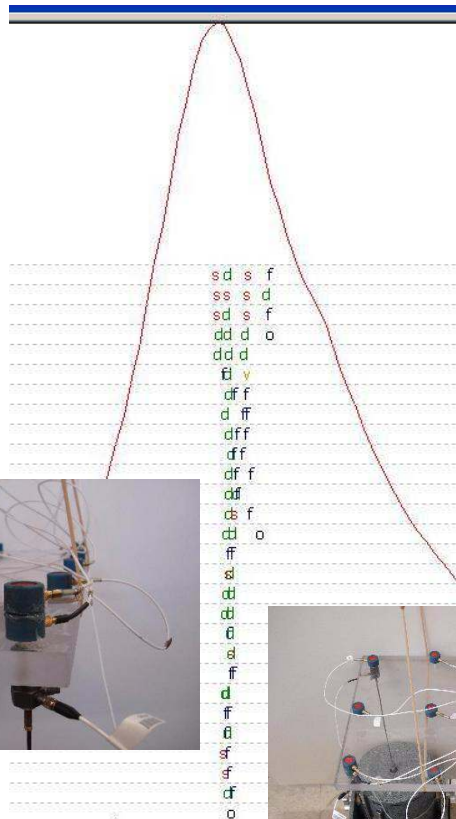

Mass Compensation

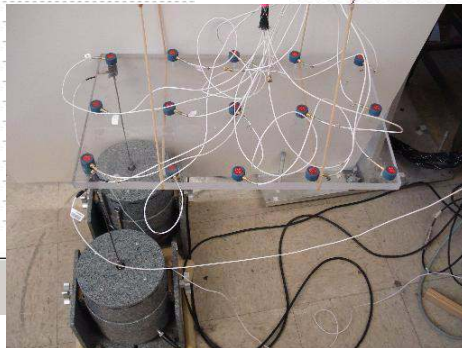
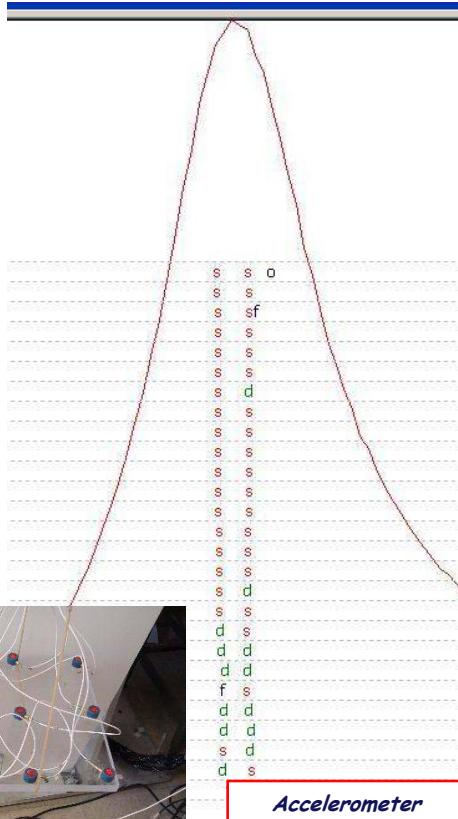

All Accels Mounted

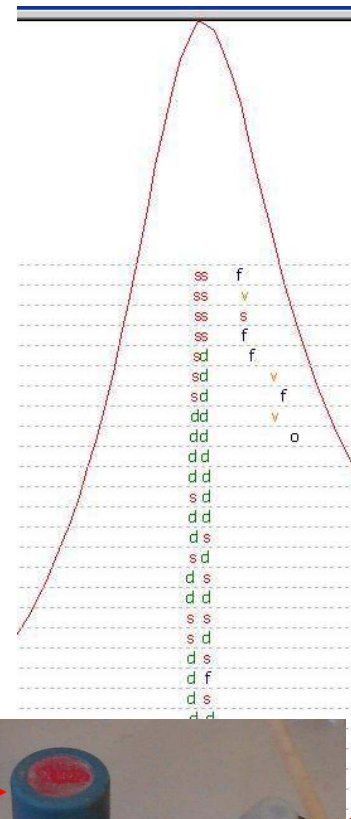

Accelerometer
and Mounting Cube

Equivalent
Mass

What's an impedance head? Why use it? Where does it go?

An impedance head is a transducer that measures both force and response in one device.

This is a critical measurement for the structure and it is strongly advised that impedance heads be used in all cases.

A combination of a separate force gage and accelerometer is often used but time and time again this measurement has been seen to never be better than that obtained with an impedance head.

The force gage or impedance head needs to be mounted on the structure side of the stinger arrangement.

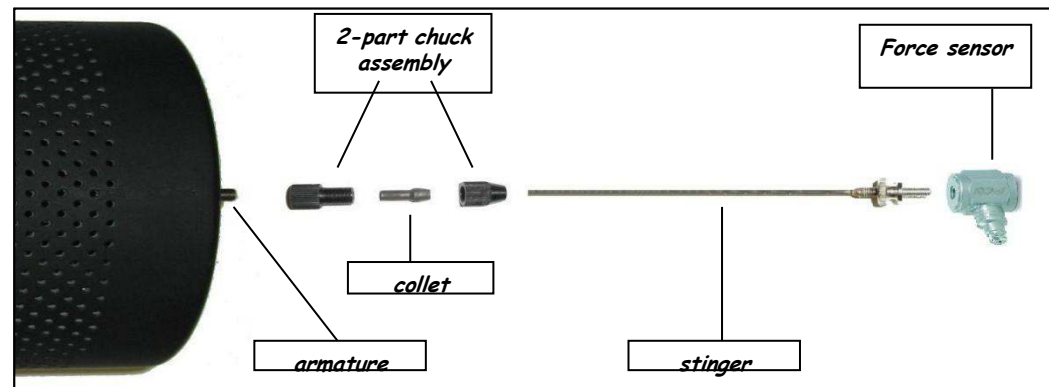

Test Set Up

Measurements taken to show difference in set up

Incorrect

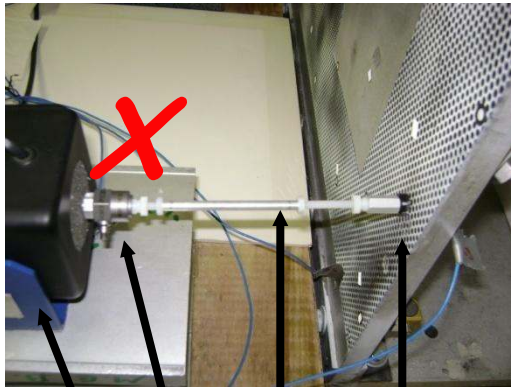

Shaker

Impedance

Quill

Structure

Correct

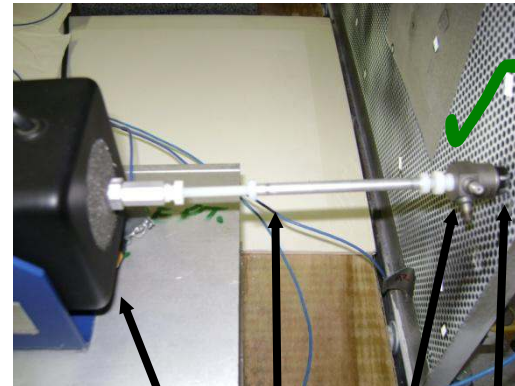

Shaker

Quill

Impedance

Structure

What is the proper mounting technique for the force transducer?

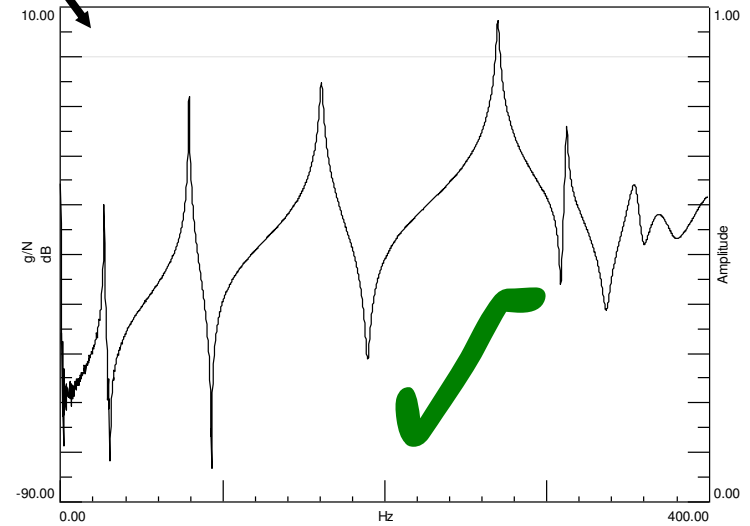
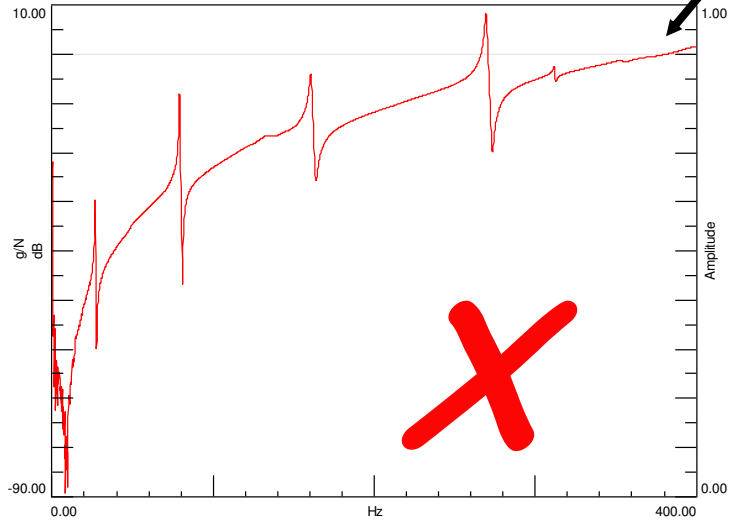
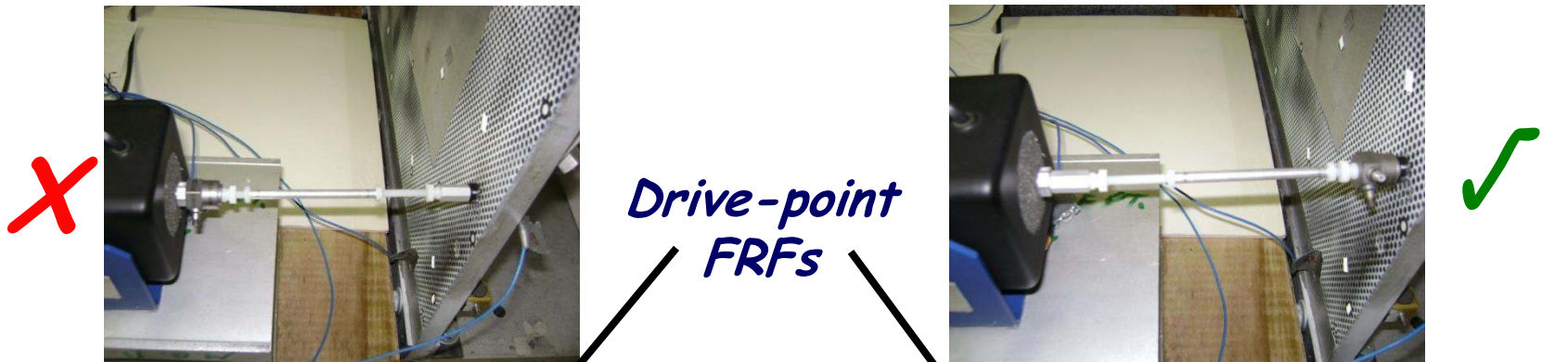

Distinct difference in drive point FRF based on force configuration !

Drive Point FRF - Stinger Effects

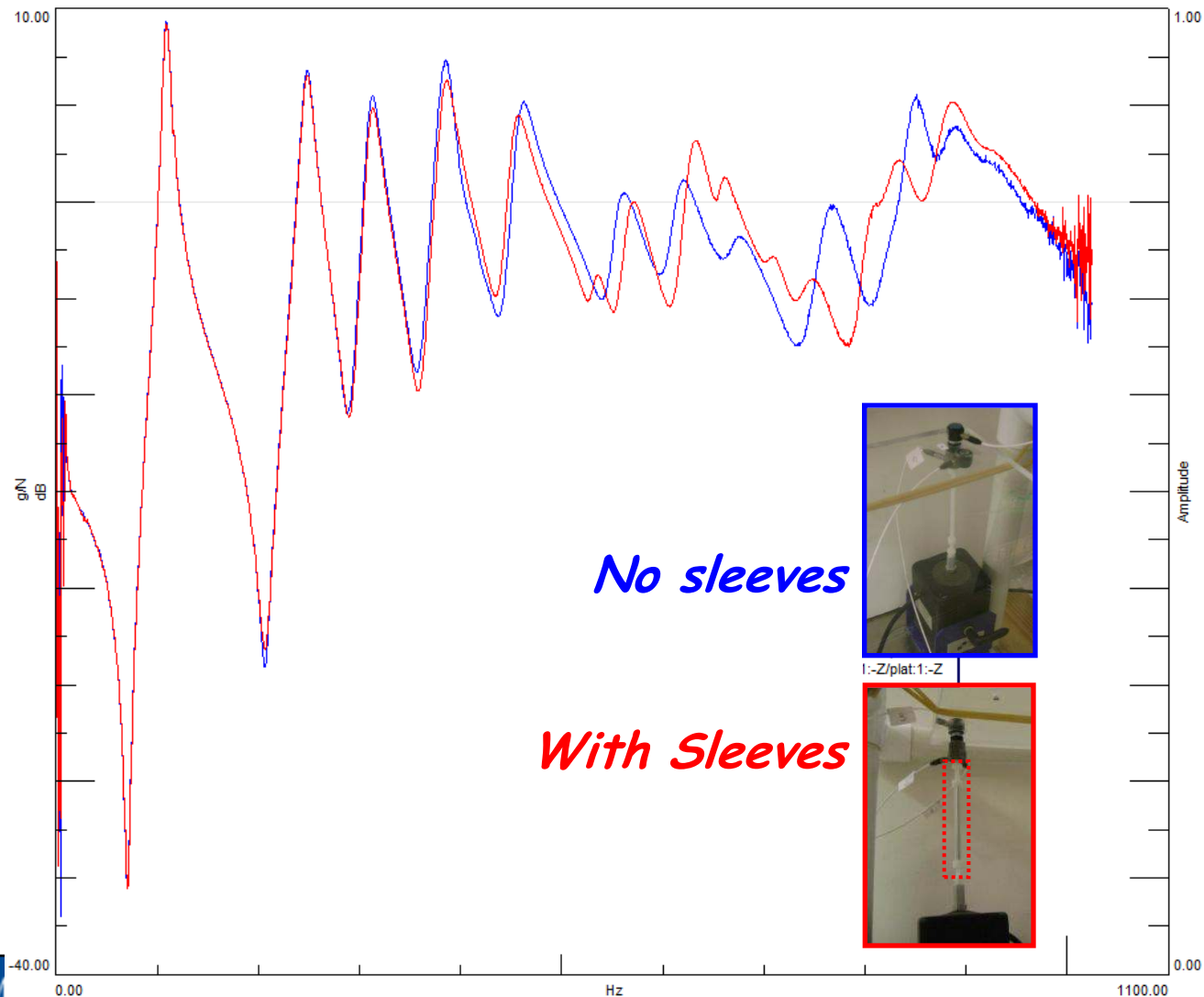

Drive Point FRF - Stinger Effects

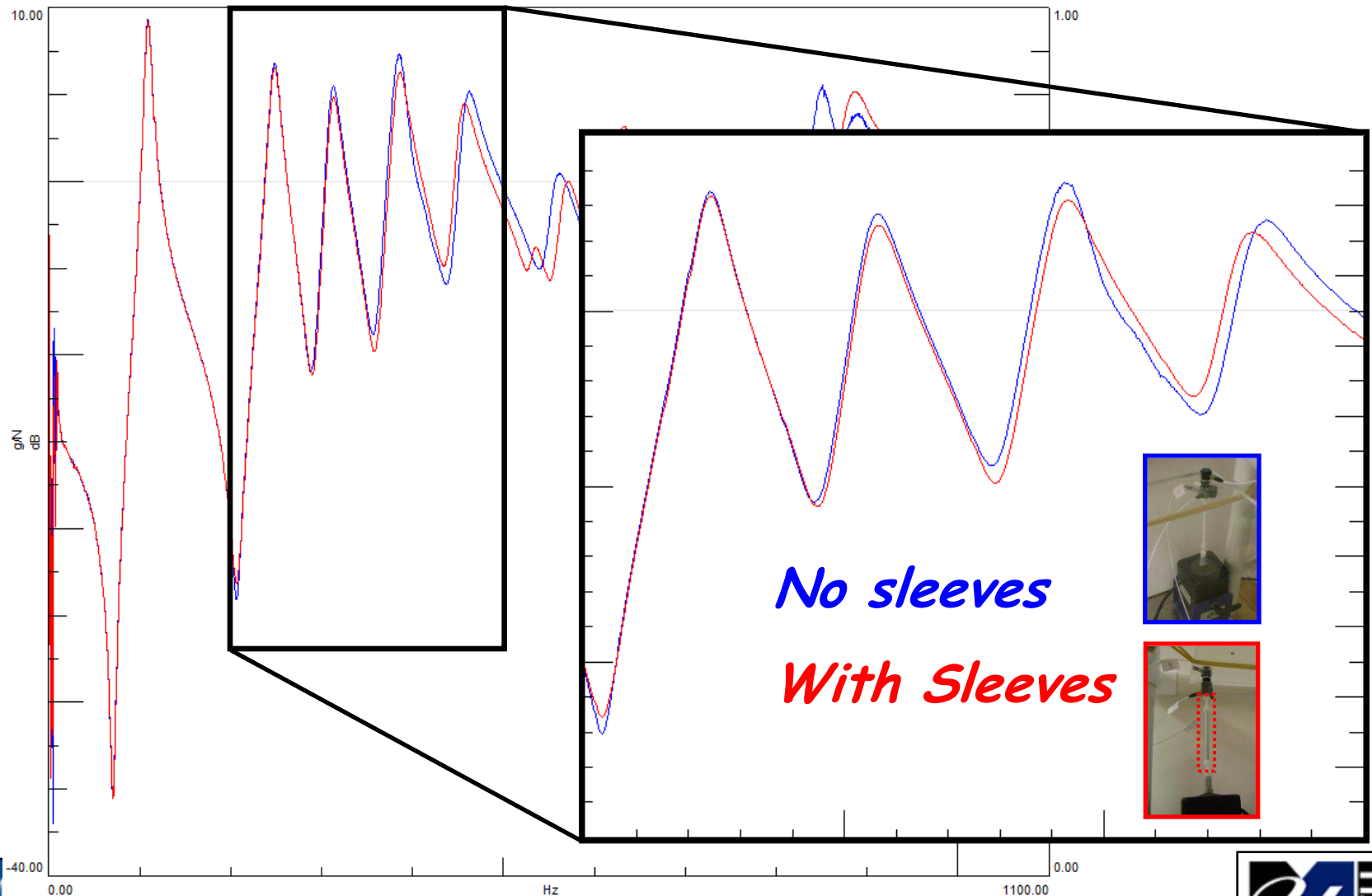

Differences in Reciprocal Measurements - Impedance vs Accel

Top View

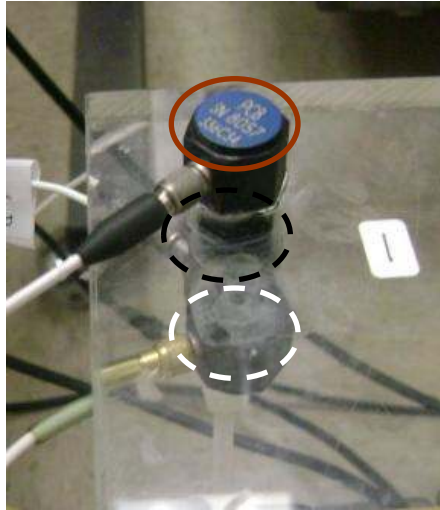

- *Offset Accelerometer*
- *Accelerometer on Other Face of Structure*
- *Impedance Head*

Bottom View

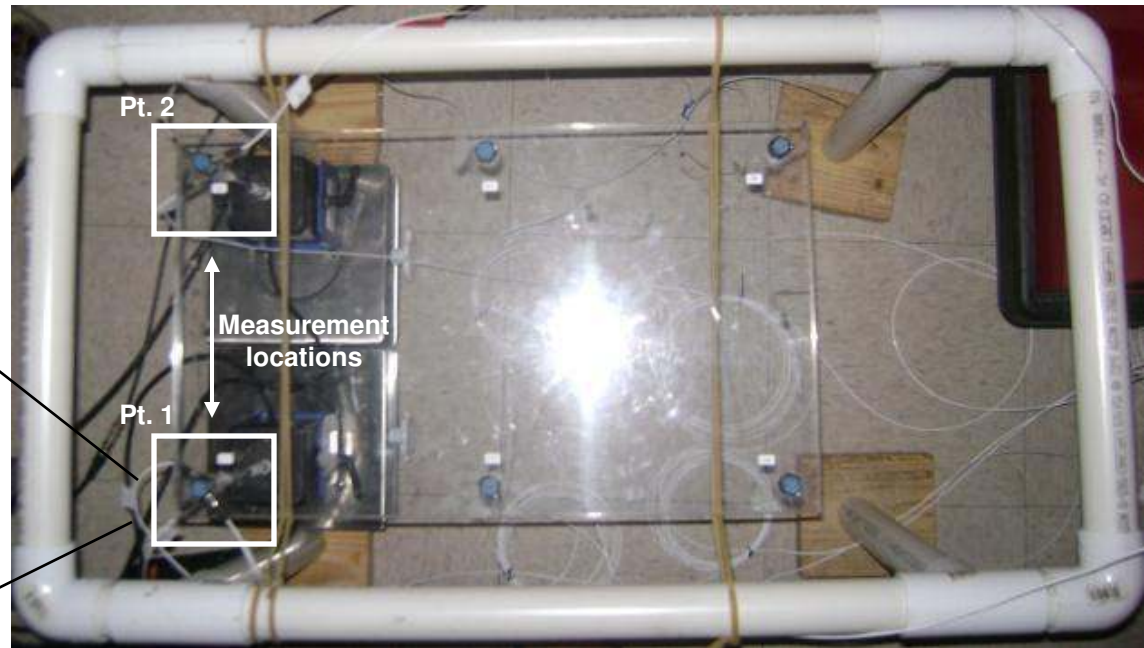
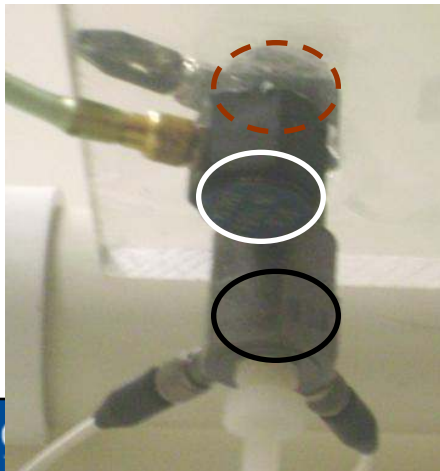

- *All reciprocity measurements are between points 1 & 2 with respect to force from impedance heads*

Reciprocal Measurements

Offset Accelerometer

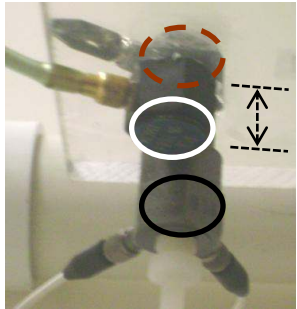

What if I can only put the accelerometer next to the force gage?

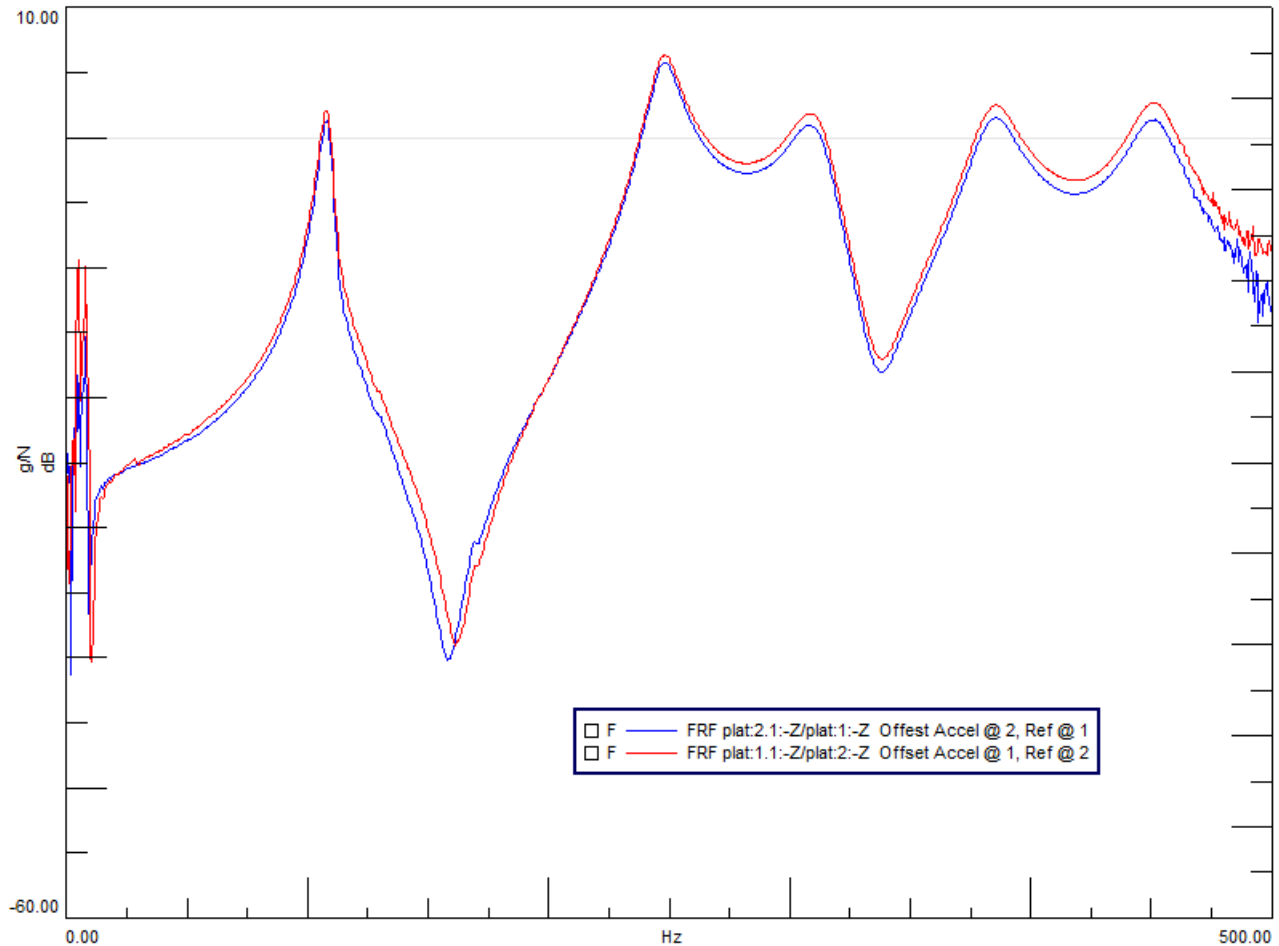
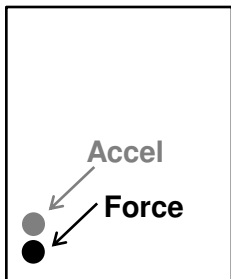

Reciprocal Measurements

Accelerometer on Other Face of Structure

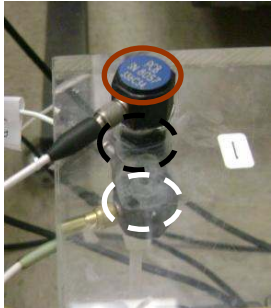

What if I can only put the accelerometer on the face of the structure that is opposite the force gage?

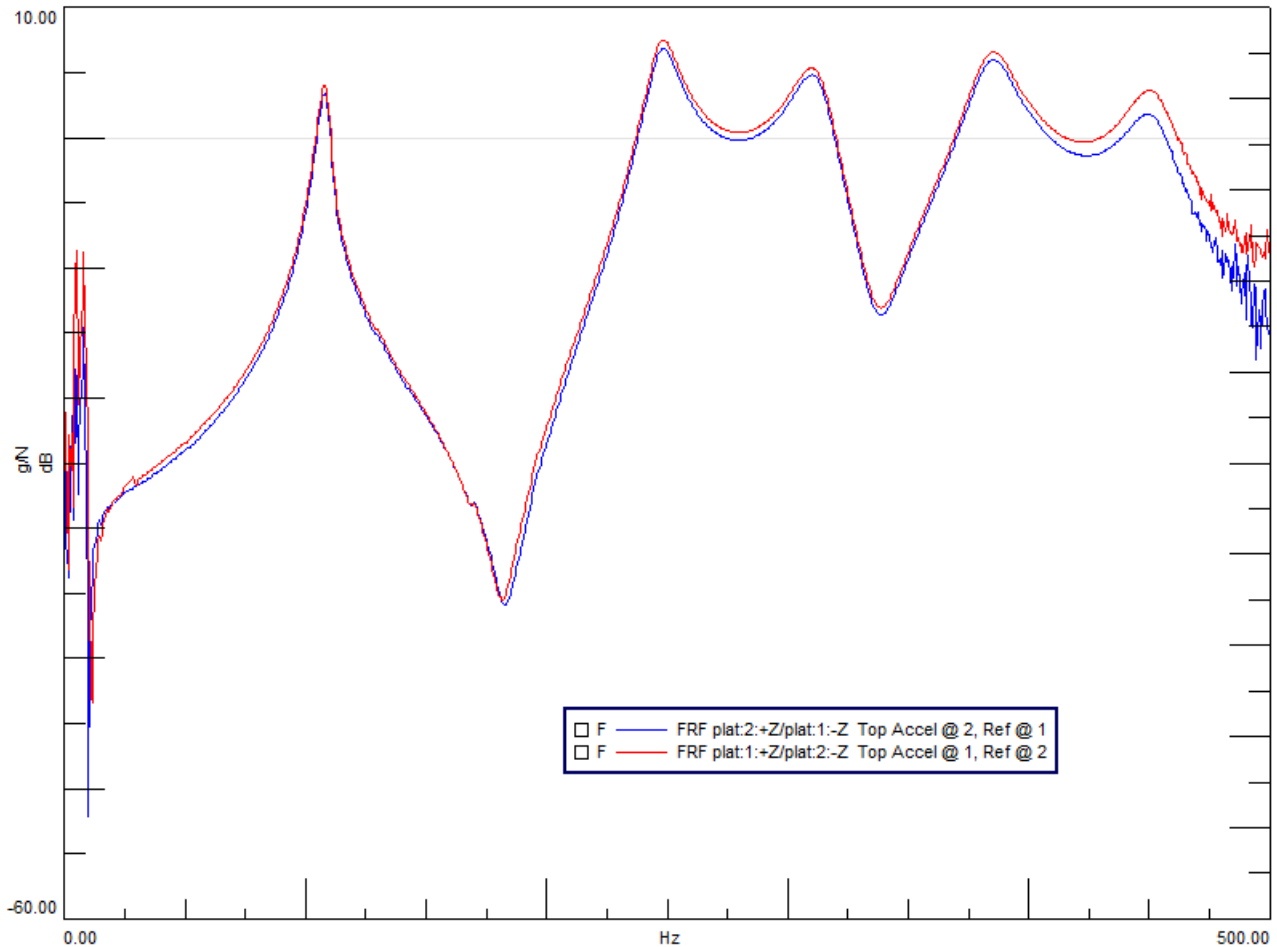
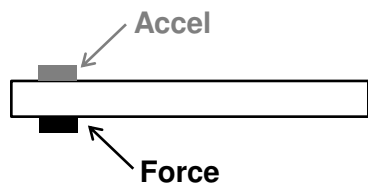

Reciprocal Measurements

Impedance Head

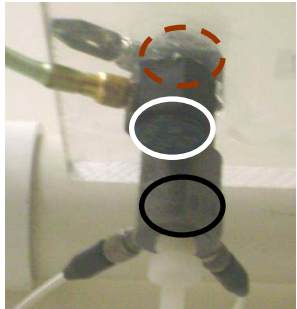

What if I have an impedance head that measures force and acceleration at the same place?

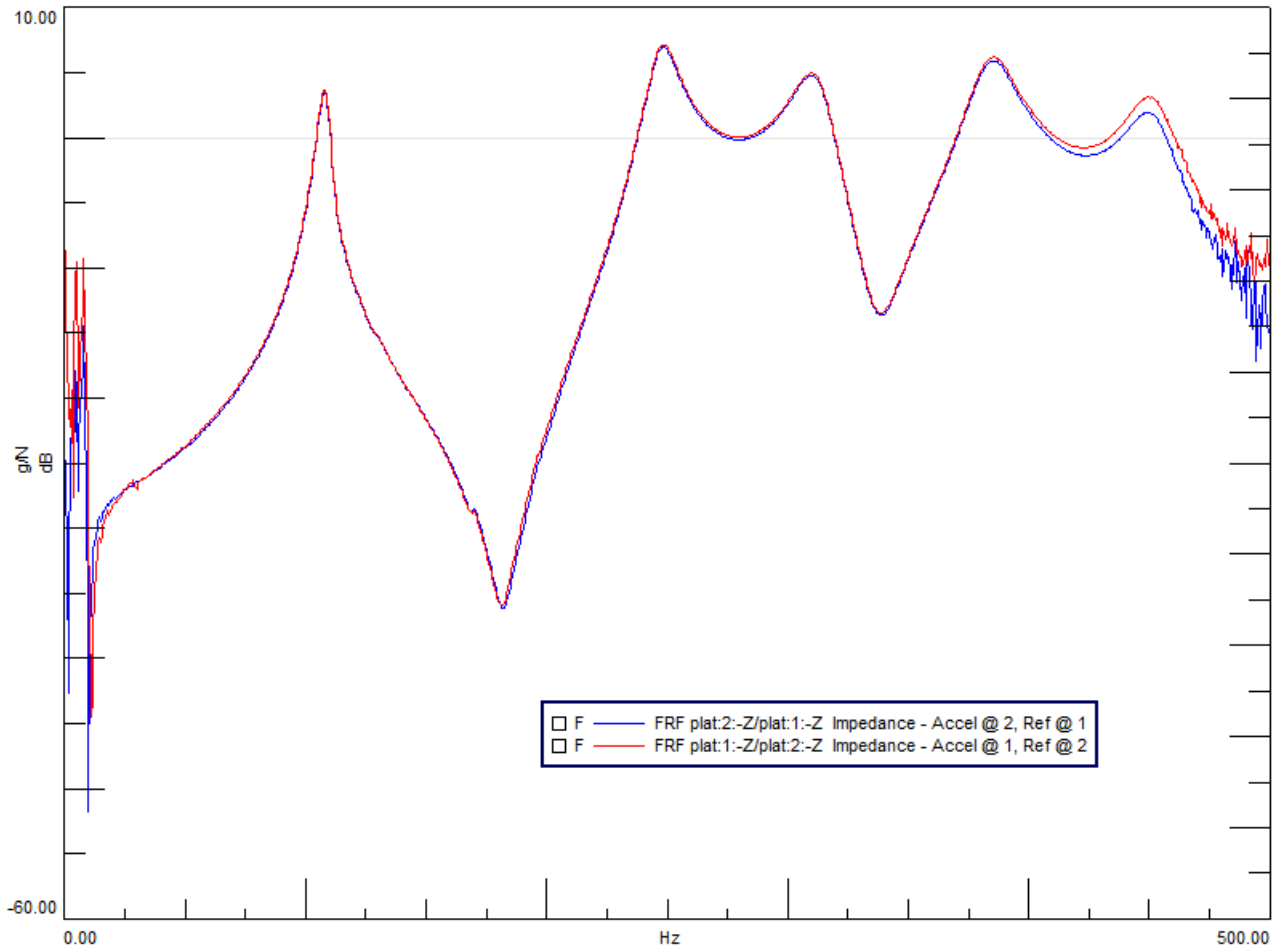
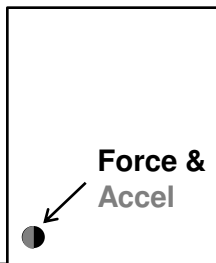

What is the correct amplitude level for modal testing applications?

The excitation levels for modal testing are usually very low.

There is no need to provide large force levels for conducting a modal test especially if appropriate response transducers (accelerometers) are selected with good sensitivity.

The level only need be sufficient to make good measurements.

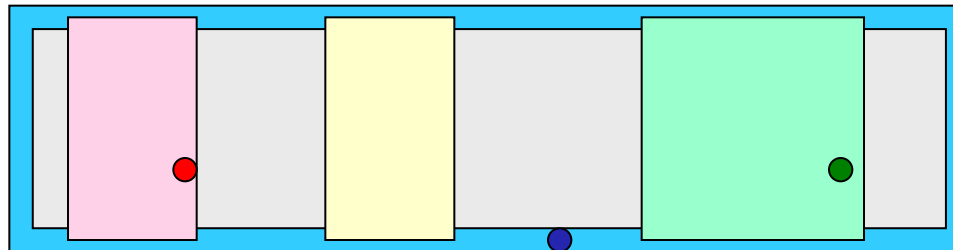

What is the correct amplitude level for modal testing applications?

The excitation levels for modal testing are usually very low.

There is no need to provide large force levels for conducting a modal test especially if appropriate response transducers (accelerometers) are selected with good sensitivity.

The level only need be sufficient to make good measurements.

In fact large force levels tend to overdrive the structure and can excite nonlinear characteristics of the structure and provide overall poorer measurements than with lower level force tests.



What is the correct amplitude level for modal testing applications?

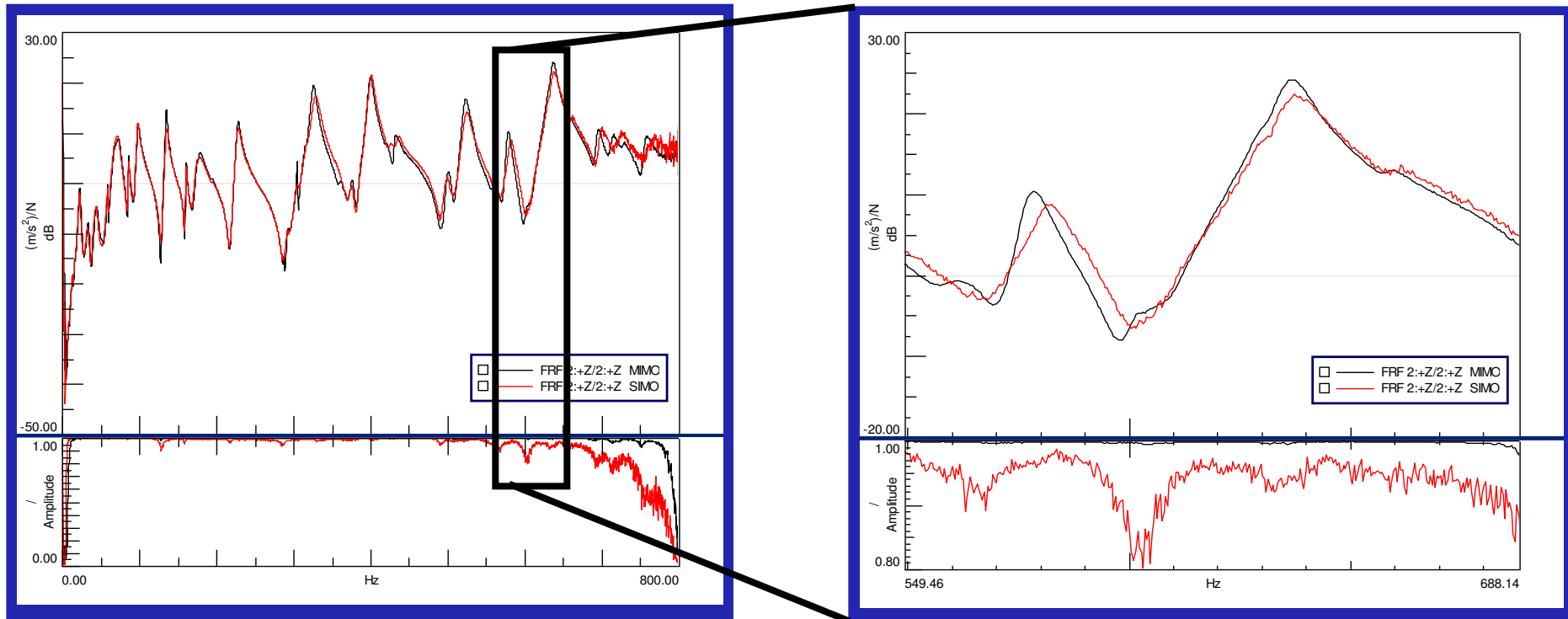

High excitation level degrades drive point FRF quality!!!

What is the correct amplitude level for modal testing applications?

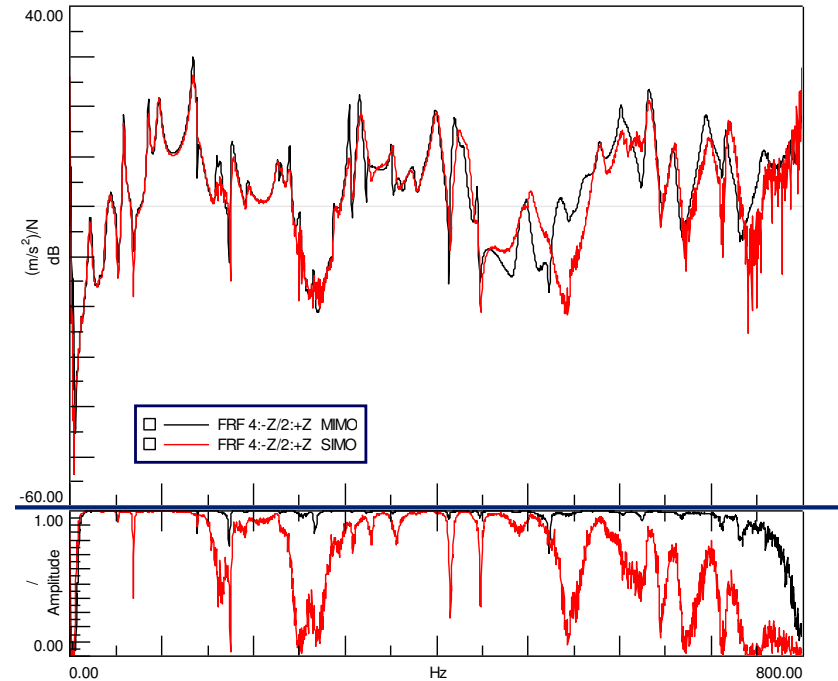

*High excitation level degrades drive point FRF quality
and measurements across components may be worse!!!*

How many shakers should I use in my modal test?

The number of shakers is often a difficult one to answer.

Basically there are never enough shakers when conducting a large modal test.

Often we are limited by the total number of shakers available in the test lab for modal testing.

Usually two shakers are sufficient for many tests. Sometimes three or four shakers are needed for much larger structures.

But generally more than five shakers are rarely used.

The main point is that there needs to be enough shakers acting as reference locations that are positioned so that all of the modes of the structure are adequately excited and good frequency response measurements are obtained.

How many shakers should I use in my modal test?

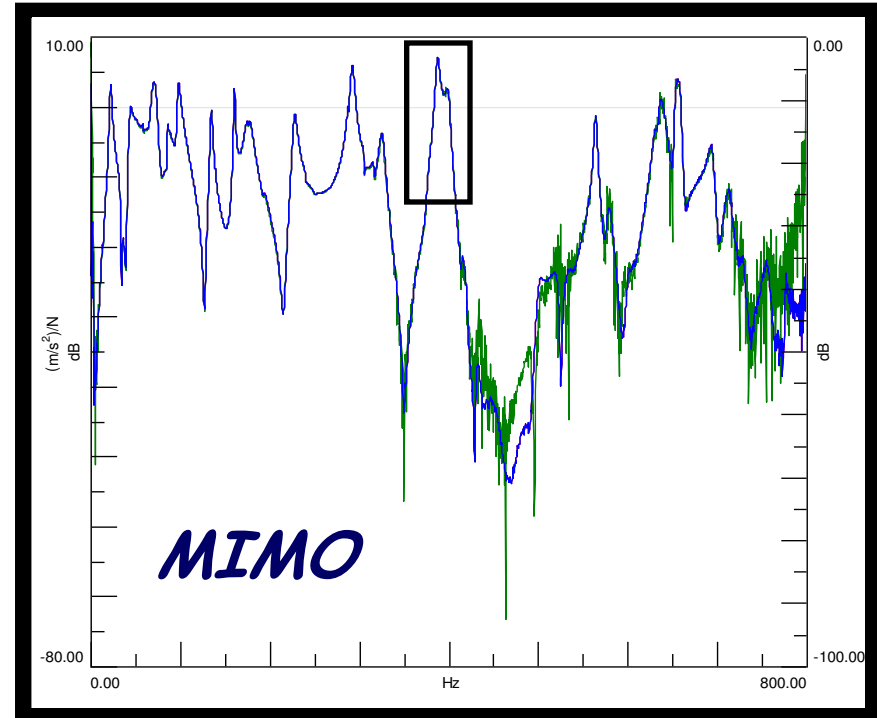
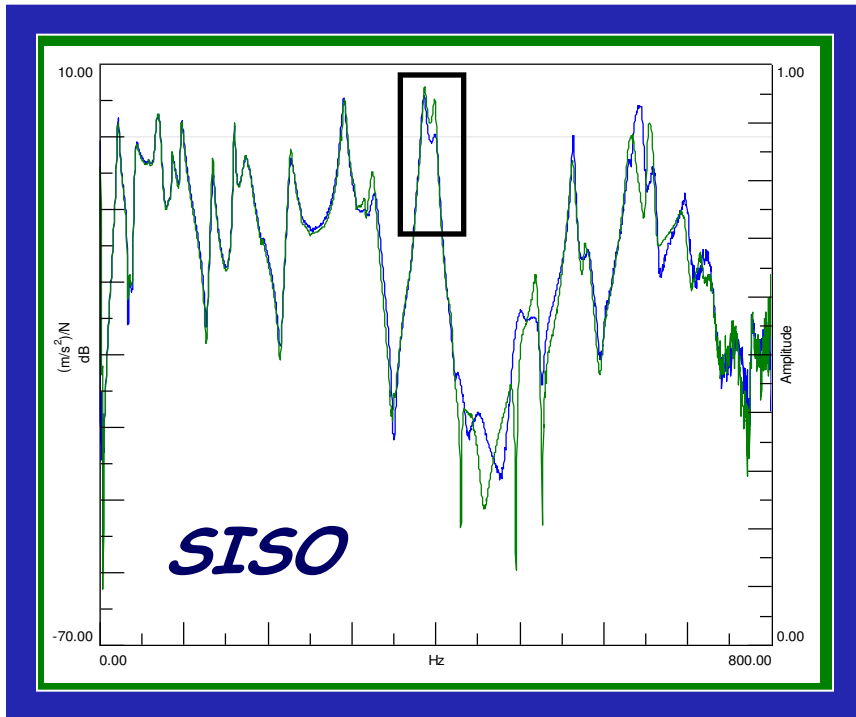

Single input may not be able to provide accurate FRFs

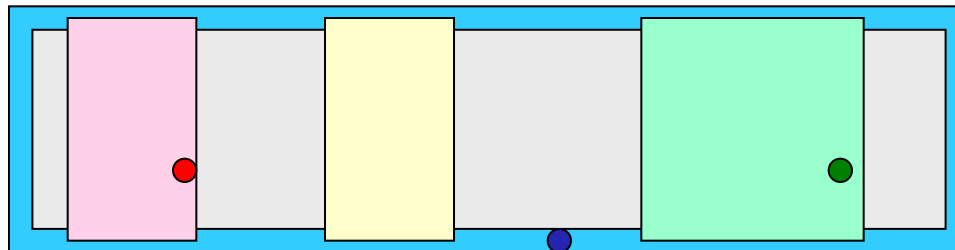

Why bother with MIMO testing? Why not run a SISO instead?

Single shaker testing is adequate providing all the modes of the structure can be sufficiently excited and measured.

In component testing this can often times be sufficient.

However, when structures have several components, then the ability to provide sufficient excitation to acquire good measurements across the whole structure may be difficult.

Tests can be conducted with a single shaker that is moved to different reference locations but generally this does not provide consistently related measurements.

When this is the case (as it often is), then MIMO is needed.

Why bother with MIMO testing? Why not run a SISO instead?

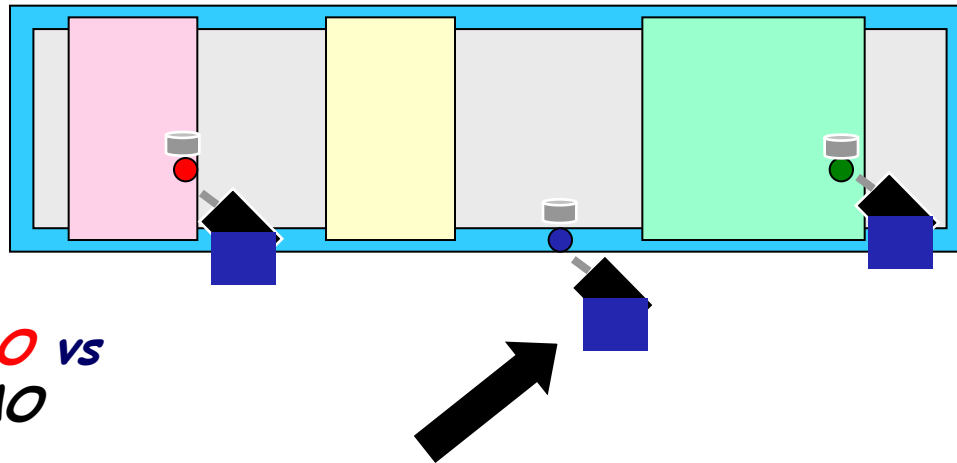

FRFs Using **SIMO** vs
FRFs Using **MIMO**

Blue Shaker is Reference for **SIMO** & **MIMO**

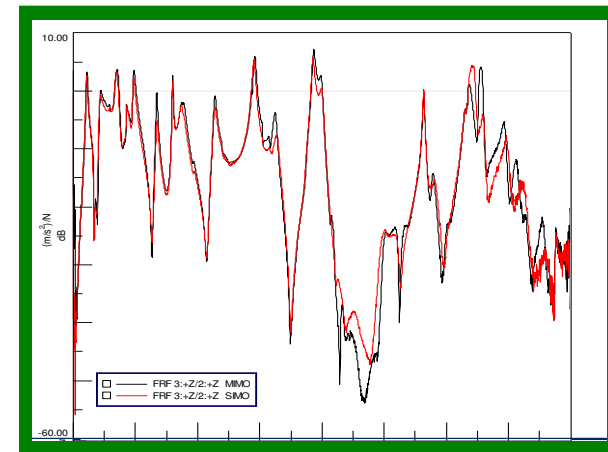
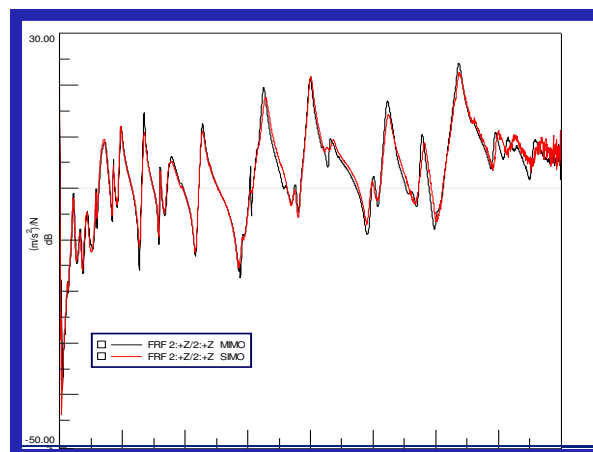
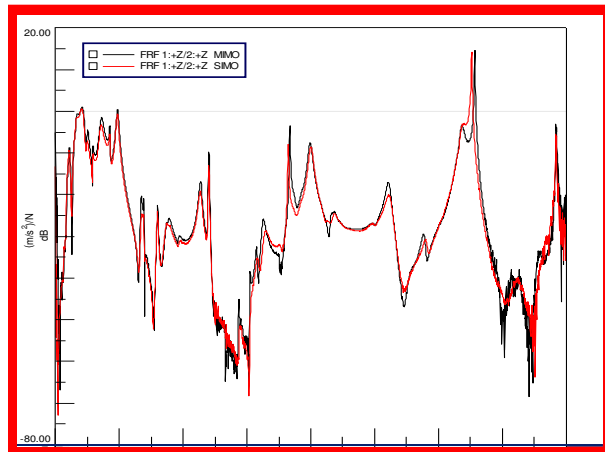

Why bother with MIMO testing? Why not run a SISO instead?

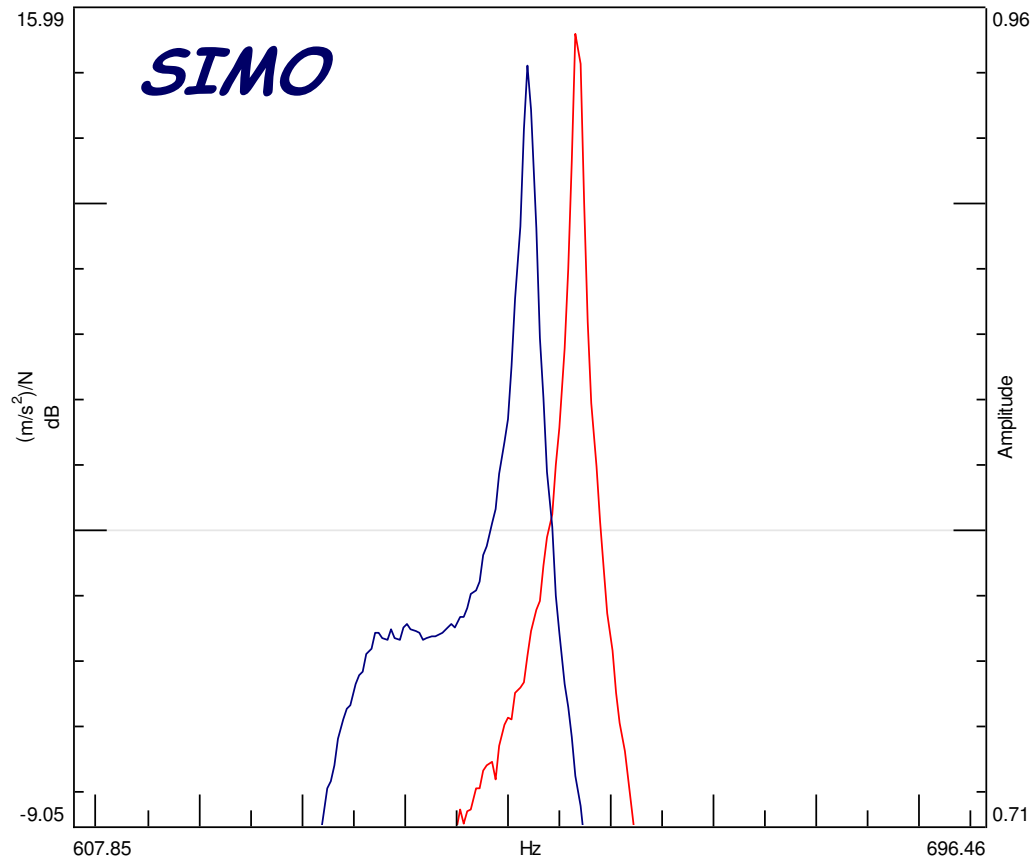

Why bother with MIMO testing? Why not run 3 SISO instead?

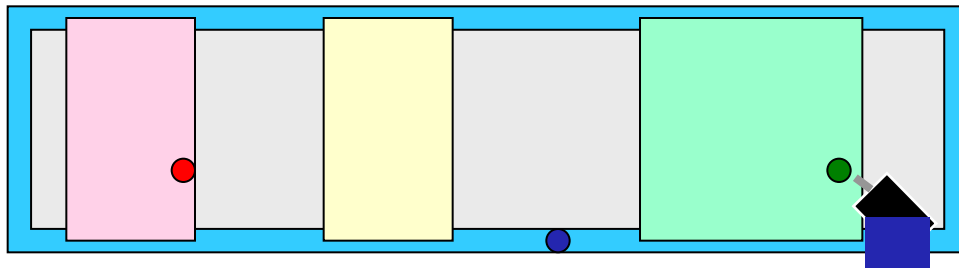
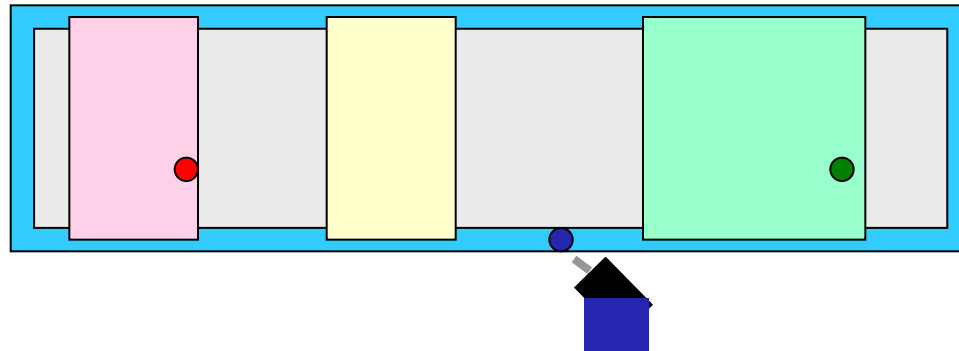
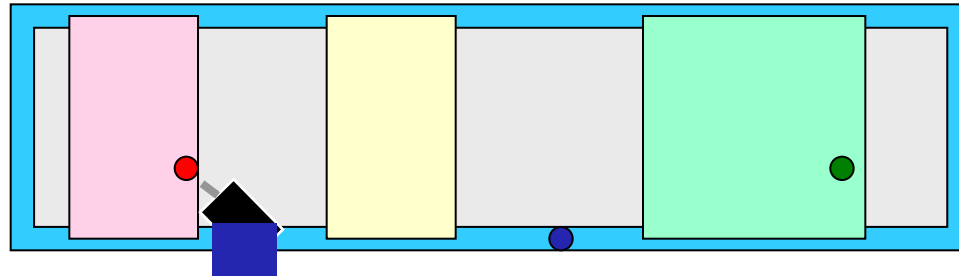

Why bother with MIMO testing? Are modal results better?

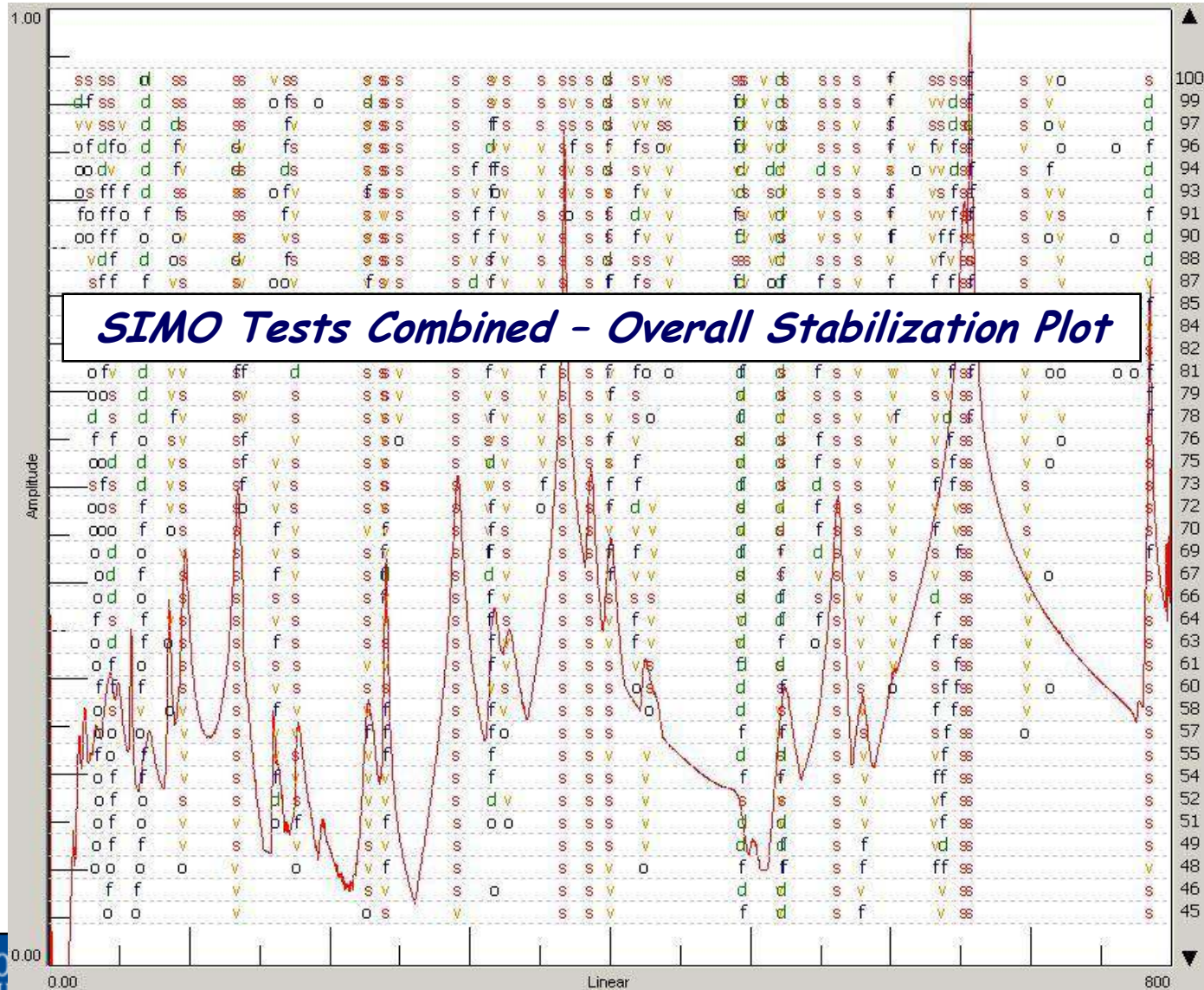

100th order
polynomial



Why bother with MIMO testing? Are modal results better?

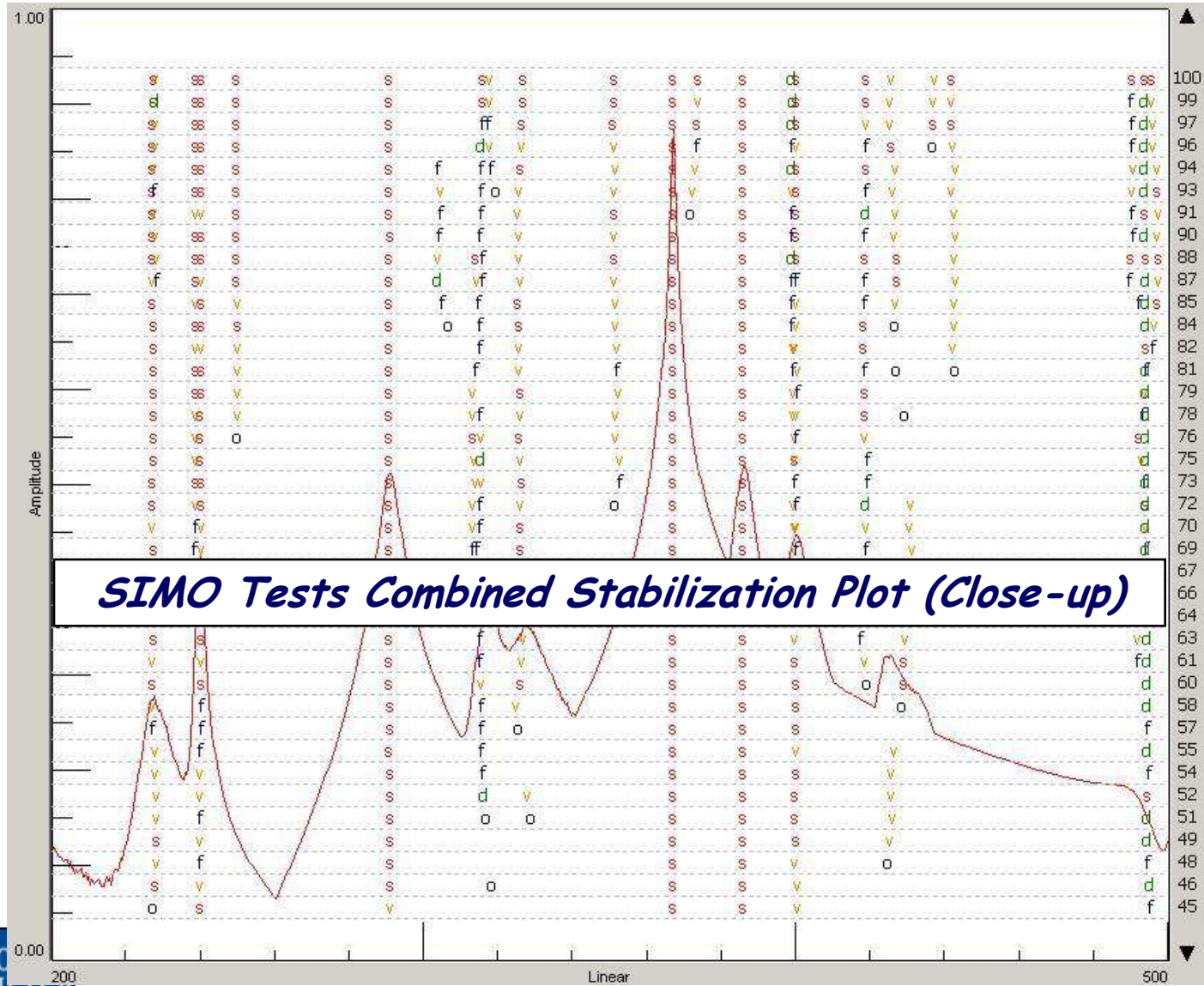

100th order polynomial



Why bother with MIMO testing? Are modal results better?

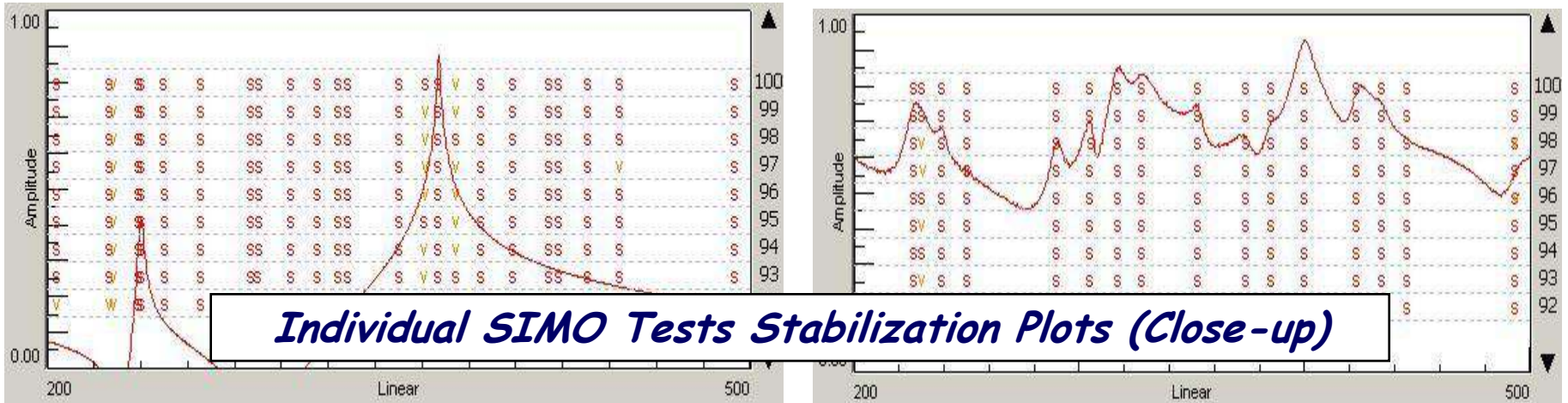

Reference Point 1

Reference Point 2

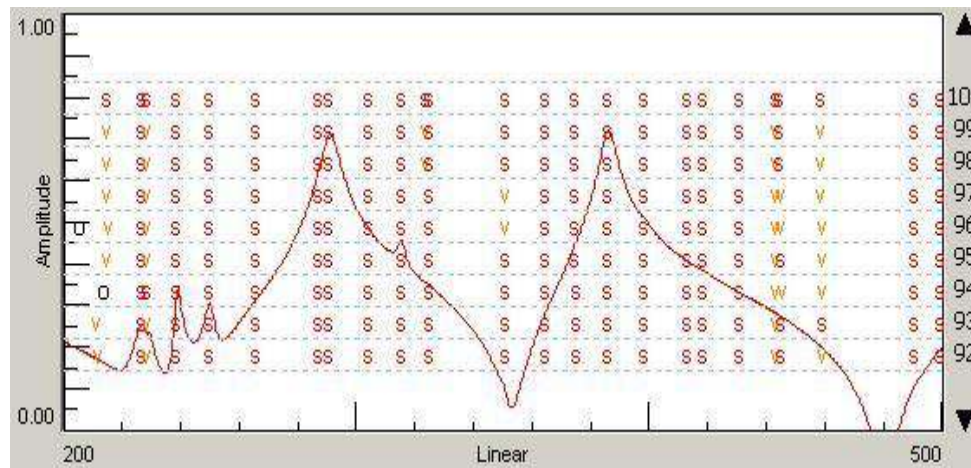

Reference Point 3

100th order polynomial



Why bother with MIMO testing? Are modal results better?

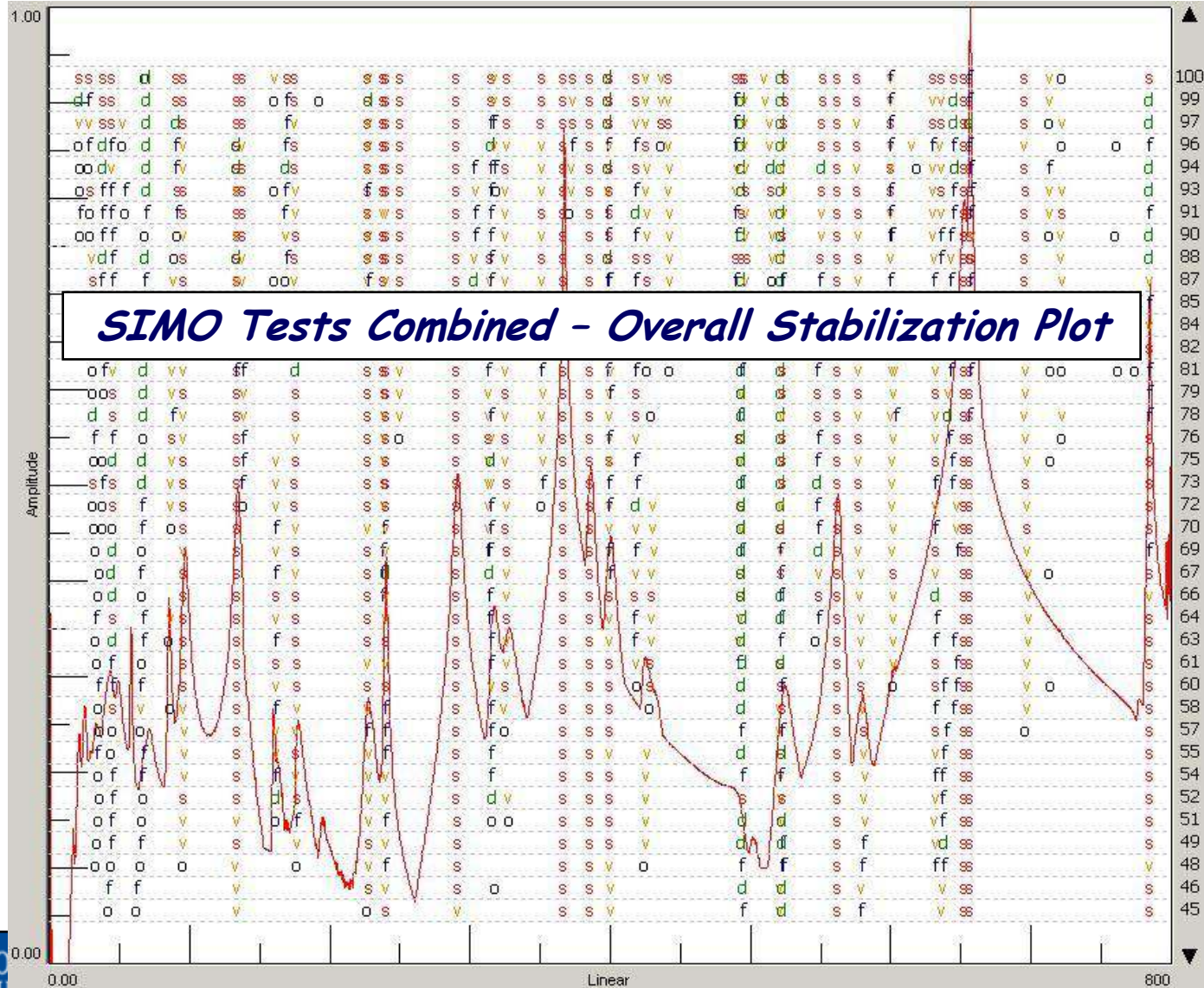

100th order
polynomial



Why bother with MIMO testing? Are modal results better?

SIMO

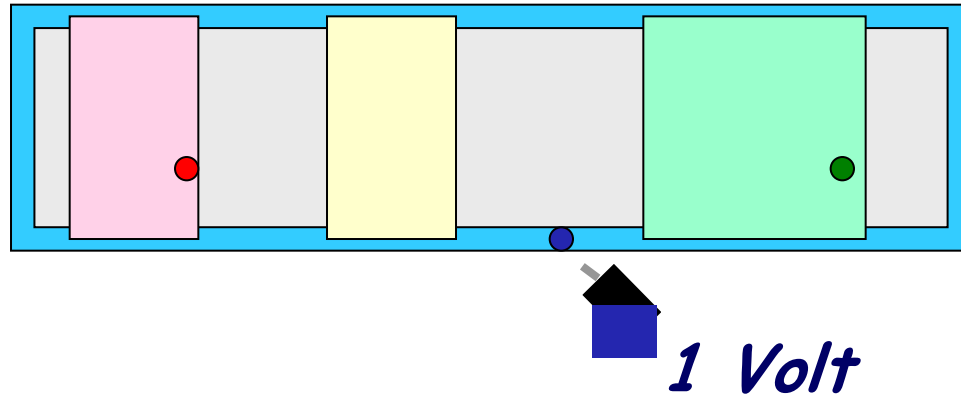

MIMO

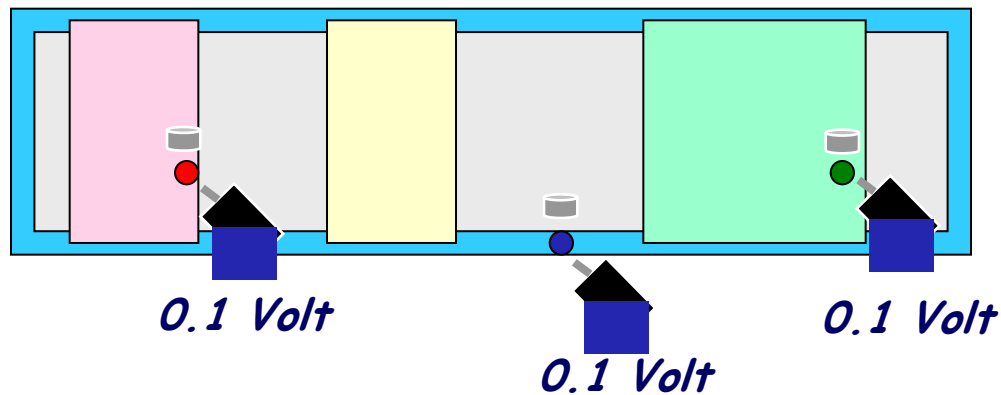

Why bother with MIMO testing? Are modal results better?

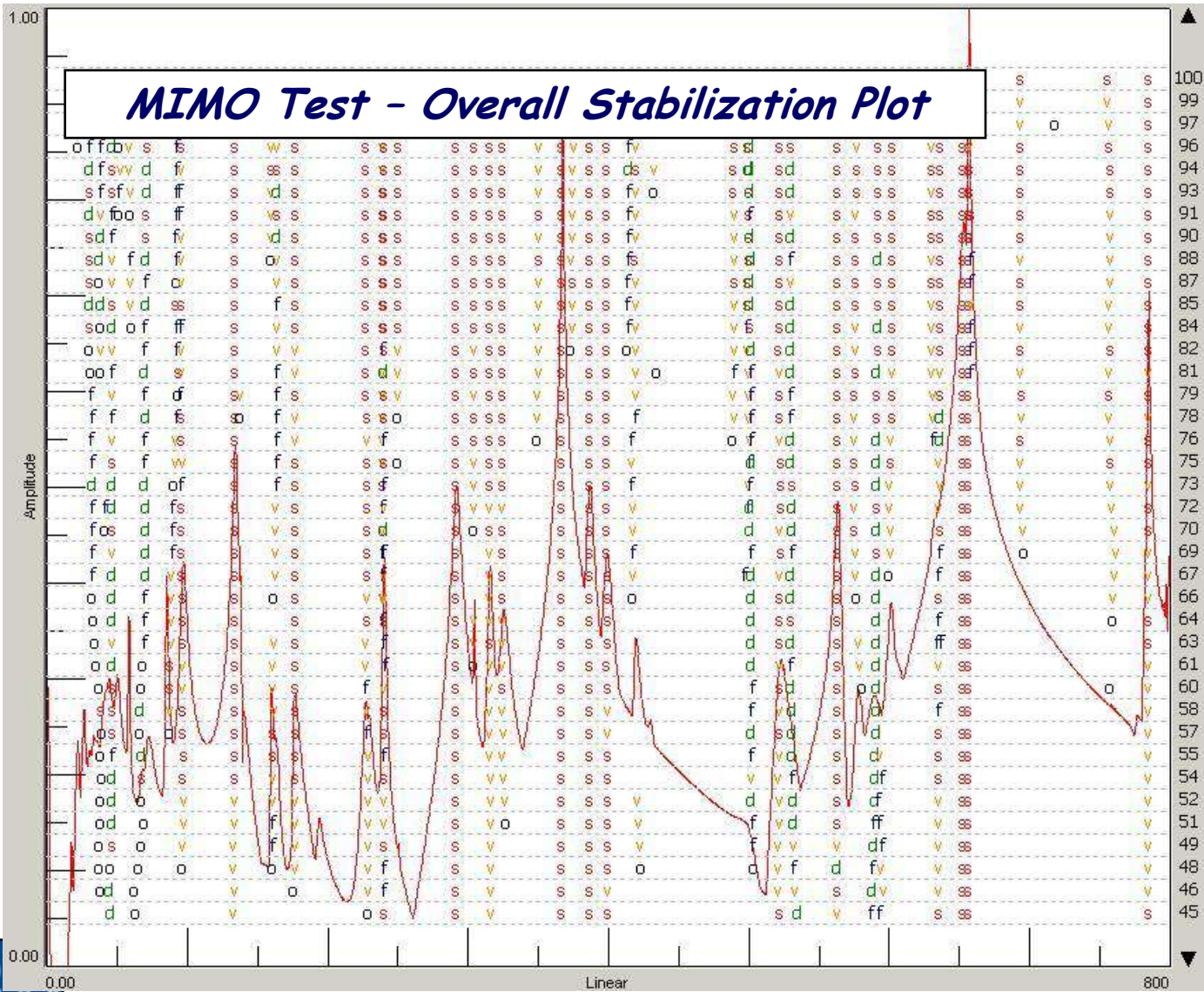

100th order polynomial



Why bother with MIMO testing? Are modal results better?

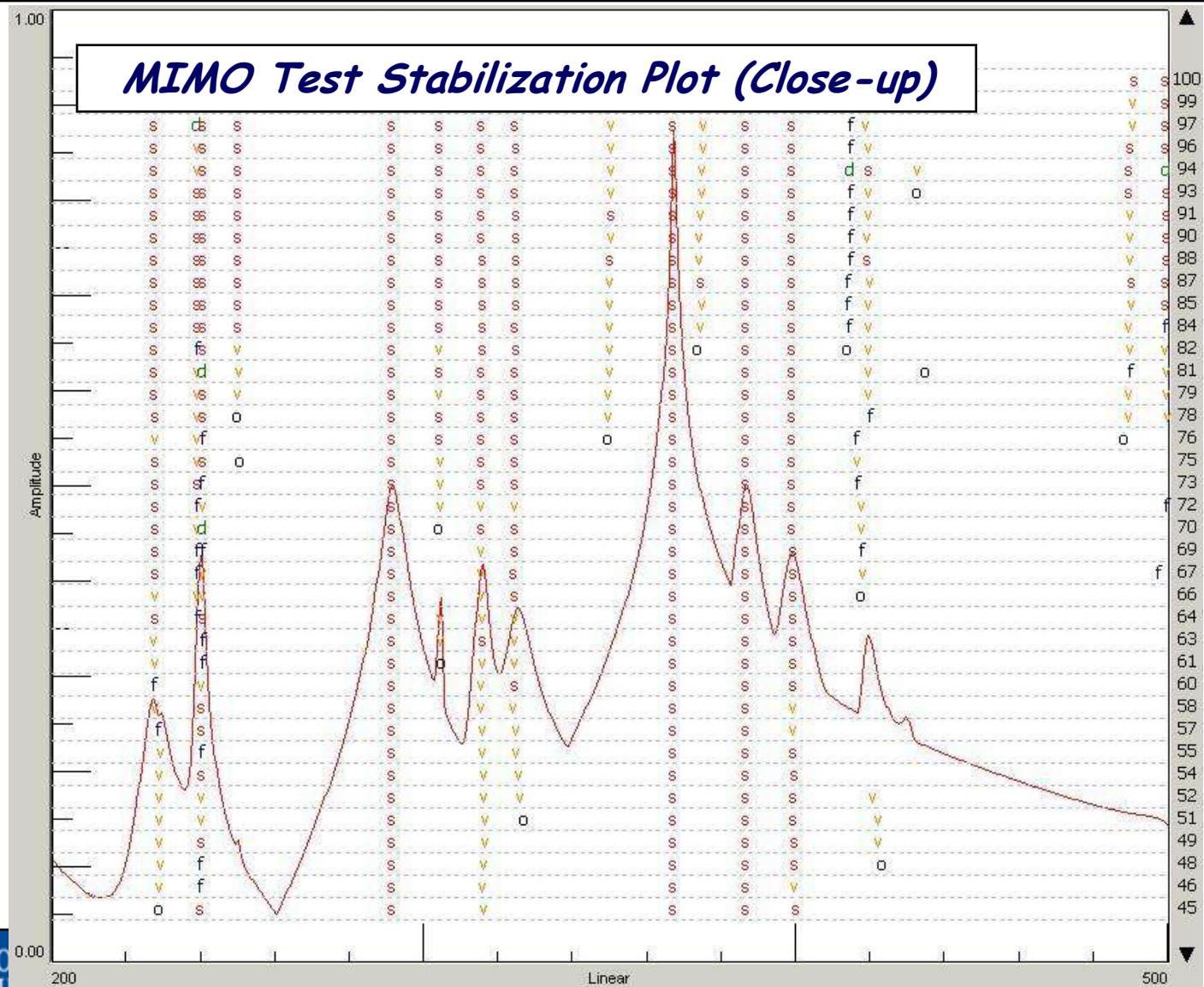

100th order polynomial



Experimental Modal - Considerations and Use

Several items are very important

- *Test Setup - boundary conditions*
- *Excitation Methods - accurate measurements*
- *Parameter Extraction - accurate parameters*
- *Dynamic Model Development*

(some personal notes from experience)



Things to Consider

Test Setup

- *Pre-Test helps in so many ways but be careful to not fully rely on the model to be correlated*
- *Do everything possible to make the best possible measurements (or the original sin results)*
- *Make sure that all measurements are consistent*
- *Be aware of all boundary conditions such as support structure, shaker stinger interaction, instrumentation effects on structure*

Things to Consider

Test Setup

- *Check for overloads and underloads of transducer*
- *Check for saturation of signal conditioning*
- *Check linearity of structure*
- *Check mass loading effects of transducers*
- *Check frequency shifts due to support condition*
- *Check frequency resolution for measurements*

Things to Consider

Measurements

- *Check every measurement including input/output time traces, power spectrum, frequency response function and coherence*
- *Check reciprocity where possible*
- *Repeat drive point measurements on test that require multiple sets of data to completely describe all points on the structure*

Things to Consider

Impact Technique

- *Check FRF with different tips, over different frequency ranges with different resolutions*
- *Maintain consistent force level for measurements*
- *Impact the same point in the same direction for each measurement*
- *Compare different number of averages to determine convergence to FRF*

Things to Consider

Shaker Excitation Technique

- *Check force/quill alignment to prevent any overturning moments on force gage*
- *Check reciprocity on MIMO tests*
- *Try multiple excitation techniques to determine what technique works best*
- *Check drive point FRFs when multiple banks of data are collected*



Excitation Techniques Do's and Don'ts



Peter Avitabile
UMASS Lowell

Marco Peres
The Modal Shop

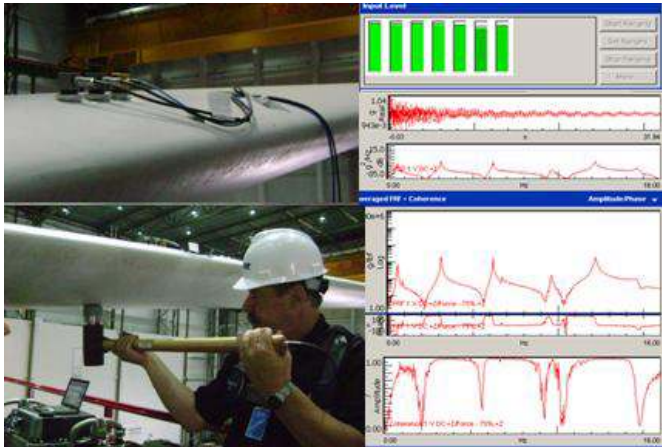

Impact Animation

